

High Efficiency Finishing Special Shape Tool Series

GALLEA

GALLEA series

*Added corner-connected R insert
for GP1LB that easy to use
for 3-axis machining.*



MOLDINO Tool Engineering, Ltd.

New Product News No.1711E-5 2020-10

GALLEA Series

GF1

GF2T

GP1LB

Combination of lens tool and barrel tool

Concept of GALLEA series

Comparison of barrel tool and ball-radius end mill

Barrel tool

Tool dia. 20mm Peripheral flute R30

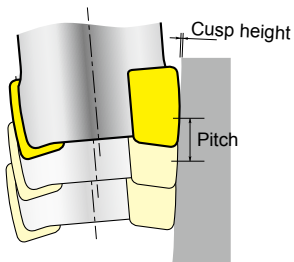

Ball end mill

Tool dia. 20mm R10

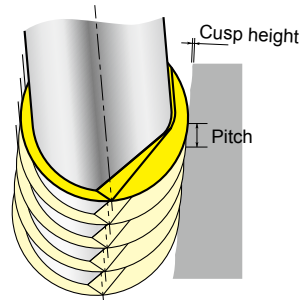

Corner radius end mill

Tool dia. 20mm Corner radius R3

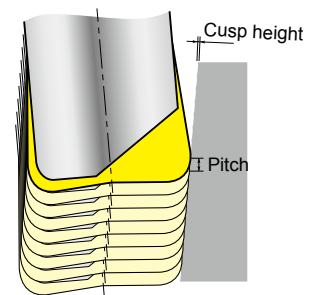

When contour milling with the same theoretical cusp height, the barrel tool can be machined with a pitch of **about 1.7 times compared with the ball end mill** of the same diameter, and **about 3 times as compared with the R3 radius end mill**.

Comparison of lens tool and ball end mill

Lens tool

Tool dia. 30mm Lens R 30

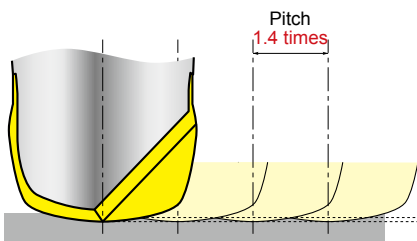

Ball end mill

Tool dia. 30mm R15

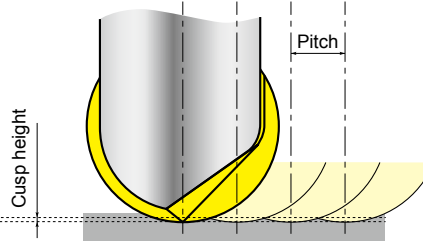

Can be machined with pitch of **about 1.4 times compared with the ball end mill** of same diameter.

Because of be able to increase the pitch, Machining time can be reduced regardless of feed speed.

3-edge,
curved surface cutting

GS4TN

GF3L

Seamless High efficiency
for 5-axis machining

GP1T

○ The same R size GALLEA series as $\phi 60$ ball end mill.

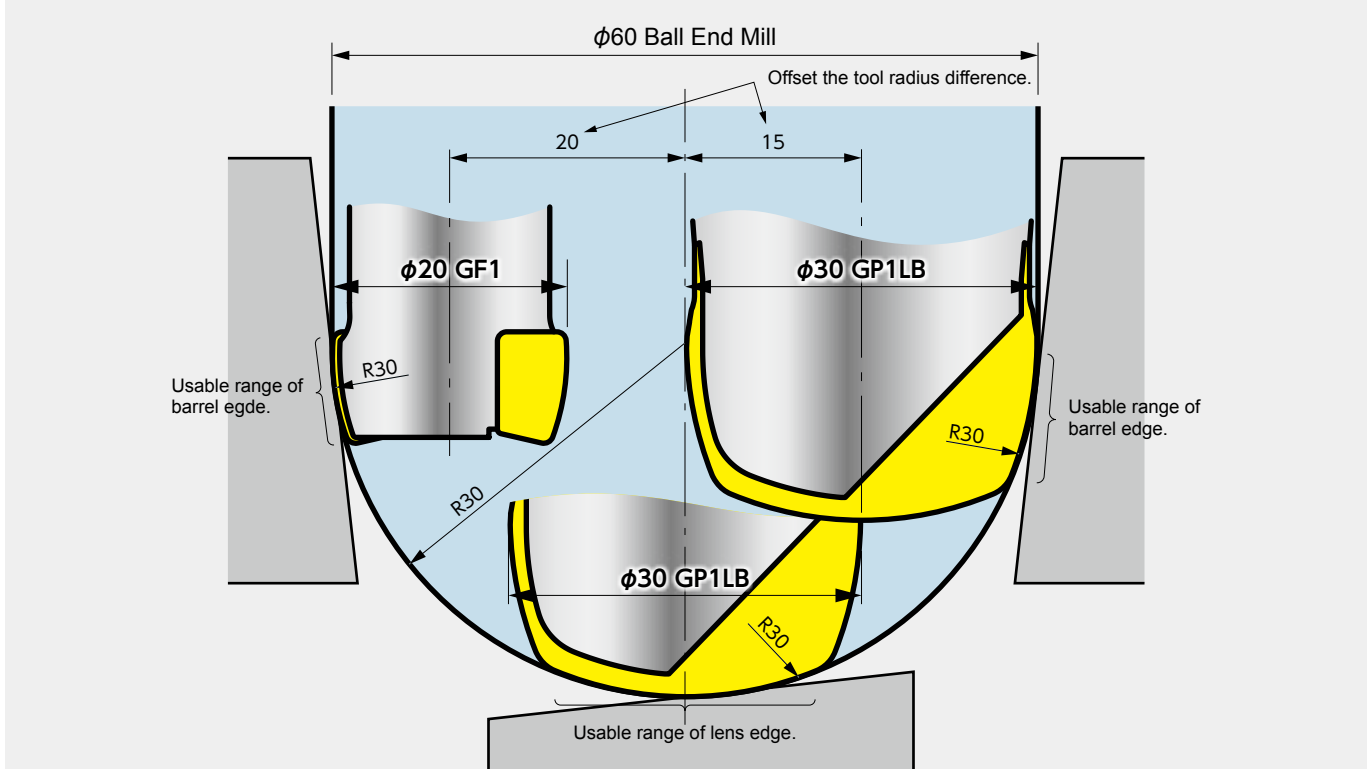

How can finishing time be reduced?

Large pitch! Small cusp!

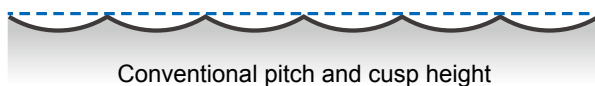

Possible to reduce the polishing time in case of same pitch condition

List of GALLEA series

Red In 3-axis machining usable range of Barrel edge

Blue In 3-axis machining usable range of Lens edge / Tip edge

Green In 3-axis machining usable range of corner-connected R

GF1 Barrel P.6

For tilted wall finishing

79°(GF1G) 71°(GF1T) R20
83°(GF1G) 78°(GF1T) R30

Finishing machining time reduced by 70%

GALLEA GF1
Max. external diameter $\phi 20\text{mm}$
Outer peripheral flute 30R

[Cutting conditions]
 $v_f=2000\text{mm/min}$ $n=4500\text{min}^{-1}$ $a_p=0.2\text{mm}$
Machining time simulation = Approx. 150 min.

[Cutting conditions]
 $v_f=2000\text{mm/min}$ $n=4500\text{min}^{-1}$ $a_p=0.6\text{mm}$
Cutting time = Approx. 40min.

GF2T Barrel P.8

For tilted wall finishing

75.1°($\phi 20$)
75.0°($\phi 25$)
74.8°($\phi 35$)
74.7°($\phi 40$)

High-performance tilted wall finishing!
Enables machining at a larger pitch than ball end mills or radius end mills.

Series expansion toward larger diameters
 $\phi 20$ $\phi 25$ $\phi 35$ $\phi 40$

Economical 2-corner specification
Unique insert holding surface enables realization of 2-corner specification.

GF3L Lens P.10

For gentle curved surfaces and gentle sloped surfaces

Semi-finishing 18°
Finishing 4° 22°

- 01** Using GALLEA series together it is possible to process from semi-finishing to finishing with high efficiency
- 02** Good sharpness positive design
- 03** High efficiency cutting tool with three edge specification
- 04** Unique insert restraining surface realizes strong insert clamping.

GP1LB Barrel, Lens P.12

For tilted wall and curved surface finishing

ZPHW000-LB00 ZPHW000-LB00-R00
72.22°($\phi 16$)
69.92°($\phi 20$)
73.79°($\phi 25$)
77.15°($\phi 30$)

Combination of lens tool and barrel tool. Precision type

Gently curved surface + Wall surface = Can be machined with a single tool.

GP1T Taper Barrel P.14

For tilted wall, curved surface and corner finishing

64°
47°

Two types of process are possible with one tool that can fully utilize the merit of 5-axis machining
Since it can work for 2 types of process without tool change, machining surface steps can be minimized.

Barrel R: This tool can take a larger pitch with a barrel R which larger than the tool radius.

Tip R: The tip can be used as a ball end mill for corner processing.

GS4TN Tangent Barrel P.18

For tilted wall, curved surface and corner finishing

69.636°

- Barrel R achieves high-efficiency and high-quality machining for tilted section
- Tip R can finish curved connecting faces to high quality
- Employs unique high helix shape and realizes low cutting force

Overview of GALLEA series

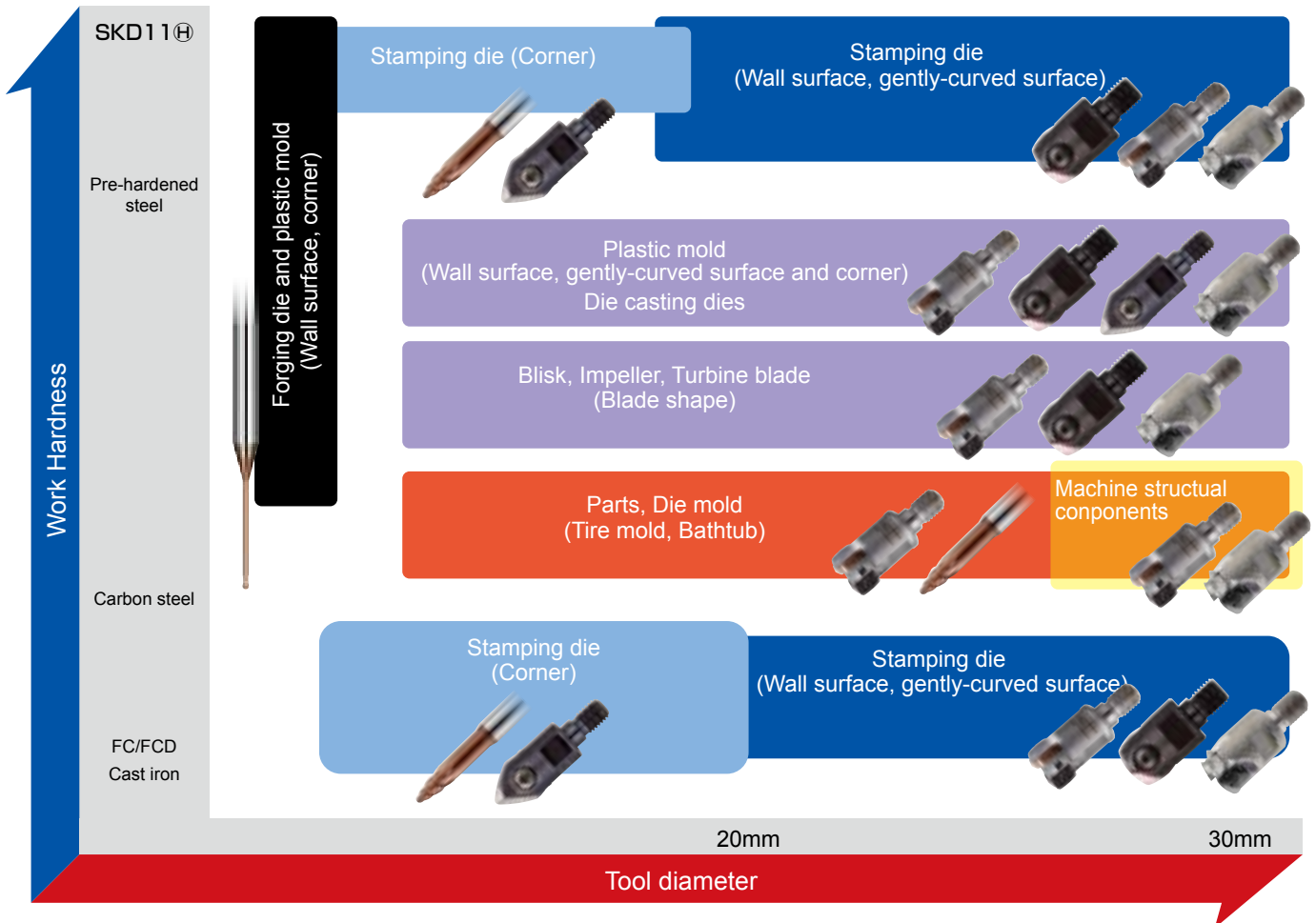

Chart of tool dia. and barrel for GALLEA series

Barrel R (mm) \ Tool dia. (mm)	2.5	3.75	5.0	7.5	10.0	12.0	16.0	20.0	25.0	30.0	35.0	40.0
12.5	GS4TN											
16.0							GP1LB					
18.75		GS4TN										
19.91									GF1T			
19.93									GF1G			
20.0								GF1T/GF1G GP1LB				
20.14							GF1G					
20.18							GF1T					
25.0			GS4TN						GP1LB			
29.78												GF2T
29.81									GF1T			
29.82									GF1G			
29.84											GF2T	
30.0						GP1T		GF1T/GF1G	GF2T	GP1LB		
30.24								GF2T				
30.33							GF1T					
30.38							GF1G					
37.5				GS4TN								
40.0							GP1T					
50.0					GS4TN			GP1T				
62.5									GP1T			
75.0										GP1T		

GF1

GF2T

GF3L

GP1LB

GP1T

GS4TN

Modular type

GF1□20○○M-○-M○○

Numeric figure in a circle ○ and Alphabetical character comes in a square □

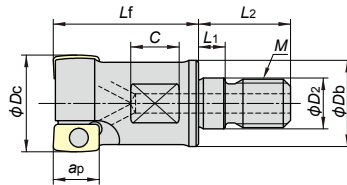

Basic type

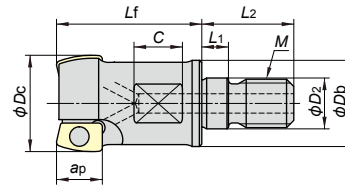

Offset type

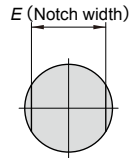

E (Notch width)

Type	Item code	Stock	No. of flutes	Size (mm)										Insert
				φDc	Lf	ap	φD2	M	φDb	L1	L2	C	E	
Basic type	GF1G2016M-2-M8	●	2	16	25	9.5	8.5	M8	14	5.5	17	8	10	XPHW0903R-20 XPHW0903R-30
	GF1G2020M-3-M10	●	3	20	30	9.5	10.5	M10	17.8	5.5	19	10	15	
	※1 GF1G2025M-4-M10	●	4	25	30	9.5	10.5	M10	17.8	5.5	19	10	15	
	GF1G2025M-4-M12	●	4	25	35	9.5	12.5	M12	22.5	5.5	22	10	17	
Offset type	GF1T2016M-2-M8	●	2	16	25	9.5	8.5	M8	14	5.5	17	8	10	YPHW0903R-20 YPHW0903R-30
	GF1T2020M-3-M10	●	3	20	30	9.5	10.5	M10	17.8	5.5	19	10	15	
	GF1T2025M-4-M12	●	4	25	35	9.5	12.5	M12	22.5	5.5	22	10	17	

[Note] When※1 and ※2 (p.16) are used together as a set, there is no interference.

Do not apply lubricants such as grease, etc. to the "contact faces" and "modular screws" of the "modular mill", "special shanks" and "special arbor".

※For information on the detailed tool shape, download the DXF data from the MOLDINO Tool Engineering home page.
(MOLDINO Tool Engineering tool selection database TOOL SEARCH: <http://data.moldino.com/toolsearch/?lang=en>)

Inserts

Basic type

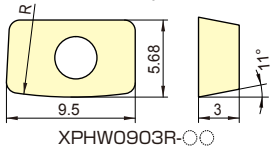

XPHW0903R-○○

Offset type

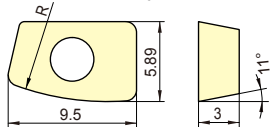

YPHW0903R-○○

P	Carbon steels, Alloy steels	■	□	■ : General cutting, First recommended □ : General cutting, Second recommended
M	SUS, etc.	■	□	
K	FC · FCD	□	■	
H	Hardened steels	■	□	
Type	Item code	PN215	TH315	Size (mm)
				R
Basic type	XPHW0903R-20	●	●	20
	XPHW0903R-30	●	●	30
Offset type	YPHW0903R-20	●	●	20
	YPHW0903R-30	●	●	30

※For information on the detailed tool shape, download the DXF data from the MOLDINO Tool Engineering home page.
(MOLDINO Tool Engineering tool selection database TOOL SEARCH: <http://data.moldino.com/toolsearch/?lang=en>)

Parts

To reduce environmental loads, drivers and screw anti-seizure agent are sold separately.
We ask for your understanding and cooperation.

Shape	Clamp screw	Not included with product (sold separately)	
		Screw driver	Screw anti-seizure agent
Cutter body			
GF1□20○○M-○-M○○	250-141	104-T8	P-37

● : Stocked Items.

Recommended cutting conditions

※Red indicates primary recommended grade.

Work material	Recommended grade	Cutting condition	φ16	φ20	φ25
Carbon steels Alloy steels (<30HRC)	※PN215	<i>n</i> (min ⁻¹)	11,950	9,560	7,650
		<i>vc</i> (m/min)	600	600	600
		<i>vf</i> (mm/min)	4,780	5,740	6,120
		<i>fz</i> (mm/t)	0.2	0.2	0.2
		<i>ap</i> (mm)	Refer right table		
		<i>ae</i> (mm)	~0.1	~0.1	~0.1
Carbon steels Alloy steels (30~45HRC)	PN215 TH315	<i>n</i> (min ⁻¹)	7,970	6,370	5,100
		<i>vc</i> (m/min)	400	400	400
		<i>vf</i> (mm/min)	3,190	3,830	4,080
		<i>fz</i> (mm/t)	0.2	0.2	0.2
		<i>ap</i> (mm)	Refer right table		
		<i>ae</i> (mm)	~0.1	~0.1	~0.1
Stainless steels SUS	PN215	<i>n</i> (min ⁻¹)	9,960	7,970	6,370
		<i>vc</i> (m/min)	500	500	500
		<i>vf</i> (mm/min)	3,990	4,790	5,100
		<i>fz</i> (mm/t)	0.2	0.2	0.2
		<i>ap</i> (mm)	Refer right table		
		<i>ae</i> (mm)	~0.1	~0.1	~0.1
Cast iron FC FCD	TH315 PN215	<i>n</i> (min ⁻¹)	11,950	9,560	7,650
		<i>vc</i> (m/min)	600	600	600
		<i>vf</i> (mm/min)	5,980	7,170	7,650
		<i>fz</i> (mm/t)	0.25	0.25	0.25
		<i>ap</i> (mm)	Refer right table		
		<i>ae</i> (mm)	~0.1	~0.1	~0.1
Hardened steels (45~55HRC)	TH315 PN215	<i>n</i> (min ⁻¹)	4,980	3,990	3,190
		<i>vc</i> (m/min)	250	250	250
		<i>vf</i> (mm/min)	1,500	1,800	1,920
		<i>fz</i> (mm/t)	0.15	0.15	0.15
		<i>ap</i> (mm)	Refer right table		
		<i>ae</i> (mm)	~0.08	~0.08	~0.08

Determine the *ap* value based on the desired cusp height by selecting it from the table below or by calculating it using the equation below.

Insert	Cusp height (mm)							
	Item code	R	0.001	0.002	0.003	0.004	0.005	0.01
XPBW0903R-20	20	0.4	0.57	0.69	0.8	0.89	1.26	
XPBW0903R-30	30	0.49	0.69	0.85	0.98	1.1	1.55	

$$a_p = 2 \sqrt{(R^2 - (R-H)^2)}$$

R : Tool R H : Cusp height

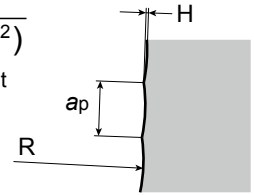

※When overhang length is 3Dc or greater, adjust the values shown in the table at left according to the table below.

Overhang ratio	<i>vc</i> (m/min)	<i>vf</i> (mm/min)
<3Dc	100%	100%
3Dc ~ 5Dc	70%	70%
5Dc ~ 6Dc	60%	60%
6Dc ~ 7Dc	50%	50%
7Dc~	45%	45%

[Note]

- ① Use the appropriate coolant for the work material and machining shape.
- ② These conditions are for general guidance; in actual machining conditions adjust the parameters according to your actual machine and work-piece conditions.
- ③ To prevent tool breakage due to chips clogging tool flutes, always be sure to use an air blower, etc. to remove chips.
- ④ Ensure to index the insert at the correct time to ensure safety of the tool-body.

Flute tip shape definitions for programing

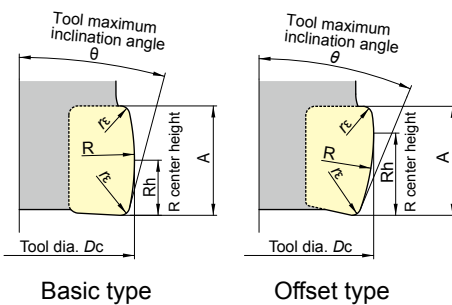

Rotation locus shape will be different depending on the combination of insert and tool diameter. Refer to the table below.

Insert item code	Basic type						Offset type					
	φ16	φ20	φ25	φ16	φ20	φ25	φ16	φ20	φ25	φ16	φ20	φ25
Tool dia. Dc (mm)	φ16	φ20	φ25	φ16	φ20	φ25	φ16	φ20	φ25	φ16	φ20	φ25
R (mm)	20.14	20	19.93	30.38	30	29.82	20.18	20	19.91	30.33	30	29.81
Rh (mm)	4.75	4.75	4.75	4.75	4.75	4.75	7.25	7.25	7.25	7.25	7.25	7.25
<i>rε</i> (mm)	0.8	0.8	0.8	0.8	0.8	0.8	0.8	0.8	0.8	0.8	0.8	0.8
A (mm)	9.5	9.5	9.5	9.5	9.5	9.5	9.5	9.5	9.5	9.5	9.5	9.5
θ	11°	11°	11°	7°	7°	7°	19°	19°	19°	12°	12°	12°

[Note] The numbers after the third decimal point are rounded off. When defining the shape parametrically, check the required dimensions from the DXF data.

Modular type

GF2T30 $\bigcirc\bigcirc\bigcirc$ M- \bigcirc

Numeric figure in a circle \bigcirc and Alphabetical character comes in a square \square

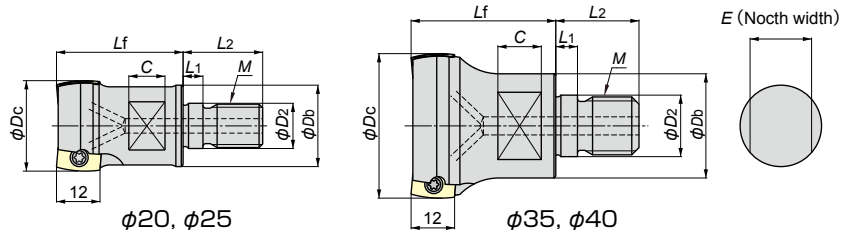

Type	Item code	Stock	No. of flutes	Size (mm)									Insert
				ϕDc	Lf	$\phi D2$	M	ϕDb	$L1$	$L2$	C	E	
Offset type	GF2T3020M-3	●	3	20	30	10.5	M10	17.8	5.5	19	10	15	YPHW1203R-30
	GF2T3025M-4	●	4	25	35	12.5	M12	22.5	5.5	22	10	17	
	※1 GF2T3035M-5	●	5	35	40	17	M16	28.8	6	23	12	22	
	※1 GF2T3040M-6	●	6	40	40	17	M16	28.8	6	23	12	22	

[Note] When ※1 and ※2 (p.16) are used together as a set, there is no interference.

Do not apply lubricants such as grease, etc. to the "contact faces" and "modular screws" of the "modular mill", "special shanks" and "special arbor".

※For information on the detailed tool shape, download the DXF data from the MOLDINO Tool Engineering home page.

(MOLDINO Tool Engineering tool selection database TOOL SEARCH: <http://data.moldino.com/toolsearch/?lang=en>)

Inserts

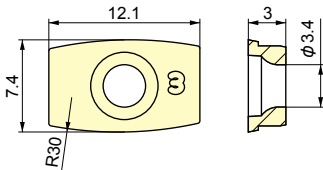
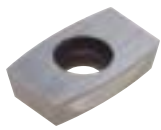

P	Carbon steels, Alloy steels	\blacksquare	\square	\blacksquare : General cutting, First recommended \square : General cutting, Second recommended
M	SUS, etc.	\blacksquare		
K	FC · FCD	\square	\blacksquare	
H	Hardened steels		\blacksquare	
Item code		Tolerance class	Grade	
YPHW1203R-30		H	PN215	TH315
			●	●

Parts

To reduce environmental loads, drivers and screw anti-seizure agent are sold separately.
We ask for your understanding and cooperation.

Shape	Clamp screw	Not included with product (sold separately)	
		Screw driver	Screw anti-seizure agent
Cutter body			
GF2T30 $\bigcirc\bigcirc\bigcirc$ M- \bigcirc	265-143 Fastening torque (N·m): 2.0	104-T10	P-37

※For information on the detailed tool shape, download the DXF data from the MOLDINO Tool Engineering home page.
(MOLDINO Tool Engineering tool selection database TOOL SEARCH: <http://data.moldino.com/toolsearch/?lang=en>)

Flute tip shape definitions for programming

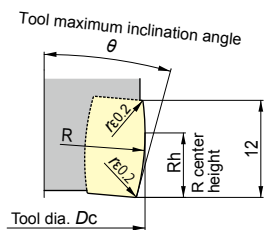

Offset type

Rotation locus shape will be different depending on the combination of insert and tool diameter.
Refer to the table below.

Insert item code	Offset type			
	YPHW1203-R30			
Tool dia. Dc (mm)	$\phi 20$	$\phi 25$	$\phi 35$	$\phi 40$
R (mm)	30.24	30	29.84	29.78
Rh (mm)	7.92	8	8	8
θ	14.9°	15°	15.2°	15.3°

[Note] The numbers after the third decimal point are rounded off. When defining the shape parametrically, check the required dimensions from the DXF data.

● : Stocked Items.

Recommended cutting conditions

※Red indicates primary recommended grade.

Work material	Recommended grade	Cutting conditions	φ20	φ25	φ35	φ40
Carbon steels Alloy steels (<30HRC)	PN215	<i>n</i> (min ⁻¹)	9,560	7,650	5,460	4,780
		<i>vc</i> (m/min)	600	600	600	600
		<i>vf</i> (mm/min)	5,740	6,120	5,460	5,740
		<i>fz</i> (mm/t)	0.2	0.2	0.2	0.2
		<i>ap</i> (mm)	Refer to the table at right.			
		<i>ae</i> (mm)	<0.1	<0.1	<0.1	<0.1
Carbon steels Alloy steels (30~45HRC)	PN215 TH315	<i>n</i> (min ⁻¹)	6,370	5,100	3,640	3,190
		<i>vc</i> (m/min)	400	400	400	400
		<i>vf</i> (mm/min)	3,830	4,080	3,640	3,830
		<i>fz</i> (mm/t)	0.2	0.2	0.2	0.2
		<i>ap</i> (mm)	Refer to the table at right.			
		<i>ae</i> (mm)	<0.1	<0.1	<0.1	<0.1
Stainless steels SUS	PN215	<i>n</i> (min ⁻¹)	7,970	6,370	4,550	3,990
		<i>vc</i> (m/min)	500	500	500	500
		<i>vf</i> (mm/min)	4,790	5,100	4,550	4,790
		<i>fz</i> (mm/t)	0.2	0.2	0.2	0.2
		<i>ap</i> (mm)	Refer to the table at right.			
		<i>ae</i> (mm)	<0.1	<0.1	<0.1	<0.1
Cast iron FC FCD	TH315 PN215	<i>n</i> (min ⁻¹)	9,560	7,650	5,460	4,780
		<i>vc</i> (m/min)	600	600	600	600
		<i>vf</i> (mm/min)	7,170	7,650	6,830	7,170
		<i>fz</i> (mm/t)	0.25	0.25	0.25	0.25
		<i>ap</i> (mm)	Refer to the table at right.			
		<i>ae</i> (mm)	<0.1	<0.1	<0.1	<0.1
Hardened steels (45~55HRC)	TH315 PN215	<i>n</i> (min ⁻¹)	3,990	3,190	2,280	2,000
		<i>vc</i> (m/min)	250	250	250	250
		<i>vf</i> (mm/min)	1,800	1,920	1,710	1,800
		<i>fz</i> (mm/t)	0.15	0.15	0.15	0.15
		<i>ap</i> (mm)	Refer to the table at right.			
		<i>ae</i> (mm)	<0.08	<0.08	<0.08	<0.08

Determine the *ap* value based on the desired cusp height by selecting it from the table below or by calculating it using the equation below.

Insert	R	Cusp height (mm)					
		0.001	0.002	0.003	0.004	0.005	0.01
YPHW1203R-30	30	0.49	0.69	0.85	0.98	1.1	1.55

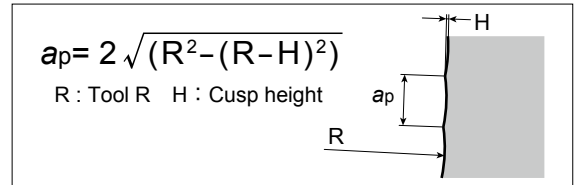

※When overhang length is 3*Dc* or greater, adjust the values shown in the table at left according to the table below.

Overhang ratio	<i>vc</i> (m/min)	<i>vf</i> (mm/min)
<3 <i>Dc</i>	100%	100%
3 <i>Dc</i> ~ 5 <i>Dc</i>	70%	70%
5 <i>Dc</i> ~ 6 <i>Dc</i>	60%	60%
6 <i>Dc</i> ~ 7 <i>Dc</i>	50%	50%
7 <i>Dc</i> ~	45%	45%

[Note]

- ① Use the appropriate coolant for the work material and machining shape.
- ② These conditions are for general guidance; in actual machining conditions adjust the parameters according to your actual machine and work-piece conditions.
- ③ To prevent tool breakage due to chips clogging tool flutes, always be sure to use an air blower, etc. to remove chips.
- ④ Ensure to index the insert at the correct time to ensure safety of the tool-body.

Field Data

Cutting of a
1°incline face

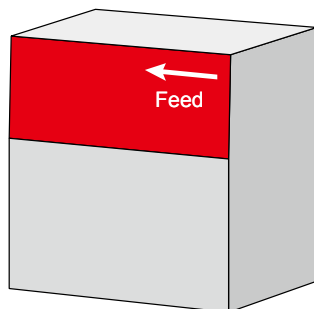

Work material : NAK80

Achieves same surface roughness at
3 times the pitch of conventional tools.



Conventional radius mill
Ra0.54μm
ap=0.2mm



GF2T3040M-6
Ra0.54μm
ap=0.6mm

Tool	Overhang length (mm)	Tool dia. (mm)	Cutting speed (m/min)	Revolution (min ⁻¹)	Feed per tooth (mm/t)	Feed rate (mm/min)	<i>ap</i> (mm)	<i>ae</i> (mm)	Coolant
GF2T3040M-6 YPHW1203R-30 PN215	245	40	160	1,273	0.1	765	0.6	0.1	Air blow
Conventional R2 radius mill							0.2		

GF1

GF2T

GF3L

GP1LB

GP1T

GS4TN

Modular type

GF3L $\circ\circ$ M-3-M $\circ\circ$

Numeric figure in a circle \circ

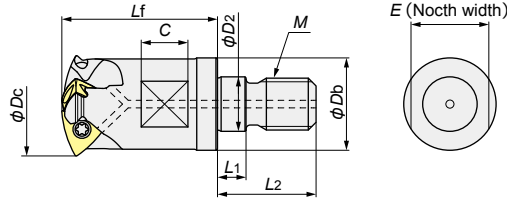

Item code	Stock	No. of Inserts	Size (mm)									Insert
			ϕDc	Lf	$\phi D2$	M	ϕDb	$L1$	$L2$	C	E	
GF3L20M-3-M10	●	3	20	30	10.5	M10	17.8	5.5	19	10	15	TPHW0902-20
GF3L25M-3-M12	●	3	25	35	12.5	M12	22.5	5.5	22	10	17	TPHW1303-25
GF3L30M-3-M16	●	3	30	40	17	M16	28.8	6	23	12	22	TPHW1403-30

[Note] Do not apply lubricants such as grease, etc. to the "contact faces" and "modular screws" of the "modular mill", "special shanks" and "special arbor".
 ※For information on the detailed tool shape, download the DXF data from the MOLDINO Tool Engineering home page.
 (MOLDINO Tool Engineering tool selection database TOOL SEARCH: <http://data.moldino.com/toolsearch/?lang=en>)

Inserts

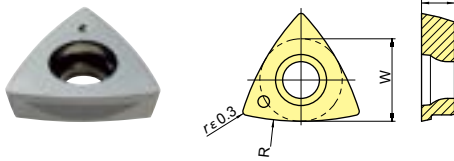

Material	General cutting	First recommended	Second recommended
P Carbon steels, Alloy steels	■	■	■
M SUS, etc.	■	■	■
K FC · FCD	■	■	■
H Hardened steels	■	■	■

Item code	Tolerance class	Grade		Size (mm)		
		PN215	TH315	W	T	R
TPHW0902-20	H	●	●	6.5	2.6	20
TPHW1303-25		●	●	8.2	3.0	25
TPHW1403-30		●	●	9.8	3.2	30

※For information on the detailed tool shape, download the DXF data from the MOLDINO Tool Engineering home page.
 (MOLDINO Tool Engineering tool selection database TOOL SEARCH: <http://data.moldino.com/toolsearch/?lang=en>)

Parts

To reduce environmental loads, drivers and screw anti-seizure agent are sold separately.
 We ask for your understanding and cooperation.

Parts	Clamp screw	Not included with product (sold separately)	
		Wrench	Screw anti-seizure agent
Shape			
Cutter body	Fastening torque (N·m)		
GF3L20M-3-M10	251-141	1.1	104-T8
GF3L25M-3-M12	265-143	2.0	104-T10
GF3L30M-3-M16	412-141	2.9	104-T15

Usable range of cutting edge for GF3L type

Semi-finishing

Finishing

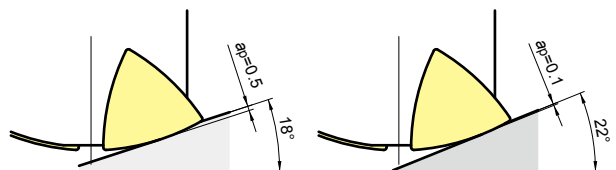

	a_p max finishing allowance	Available cutting range
Semi-finishing	0.5mm	18°
Finishing	0.1mm	22°

Because of GF3L type does not have a peripheral cutting edge, cutting range changes according to cutting depth (a_p).

Correction of tool length measurement value

GF3L type does not have cutting edge in the tool center. When create toolpath with lens tool definition, correct the measurement value of tool length. When using a CAM that can define a tool shape with CAM and DXF data that can define a tool shape, it is unnecessary to correct the tool length measurement value.

	Correction (mm)	Tip dia. (mm)
GF3L20M-3-M10	0.058	3.0
GF3L25M-3-M12	0.056	3.3
GF3L30M-3-M16	0.062	3.9

● : Stocked Items.

Recommended cutting conditions

※Red indicates primary recommended grade.

Work material	Recommended grade	Cutting condition	Finishing			Semi-finishing		
			φ20	φ25	φ30	φ20	φ25	φ30
Carbon steels Alloy steels (<30HRC)	PN215	<i>n</i> (min ⁻¹)	11,470	9,180	7,650	4,780	3,830	3,190
		<i>vc</i> (m/min)	720	720	720	300	300	300
		<i>vf</i> (mm/min)	6,890	5,510	4,590	7,170	5,750	4,790
		<i>fz</i> (mm/t)	0.2	0.2	0.2	0.5	0.5	0.5
		<i>ap</i> (mm)	0.1	0.1	0.1	0.5	0.5	0.5
		<i>ae</i> (mm)	Refer below table			Refer below table		
Carbon steels Alloy steels (30~45HRC)	PN215 TH315	<i>n</i> (min ⁻¹)	8,290	6,630	5,530	3,190	2,550	2,130
		<i>vc</i> (m/min)	520	520	520	200	200	200
		<i>vf</i> (mm/min)	4,980	3,980	3,320	4,790	3,830	3,200
		<i>fz</i> (mm/t)	0.2	0.2	0.2	0.5	0.5	0.5
		<i>ap</i> (mm)	0.1	0.1	0.1	0.5	0.5	0.5
		<i>ae</i> (mm)	Refer below table			Refer below table		
Stainless steels SUS	PN215	<i>n</i> (min ⁻¹)	7,970	6,370	5,310	4,780	3,830	3,190
		<i>vc</i> (m/min)	500	500	500	300	300	300
		<i>vf</i> (mm/min)	4,790	3,830	3,190	7,170	5,750	4,790
		<i>fz</i> (mm/t)	0.2	0.2	0.2	0.5	0.5	0.5
		<i>ap</i> (mm)	0.1	0.1	0.1	0.5	0.5	0.5
		<i>ae</i> (mm)	Refer below table			Refer below table		
Cast iron FC FCD	TH315 PN215	<i>n</i> (min ⁻¹)	10,360	8,290	6,910	6,370	5,100	4,250
		<i>vc</i> (m/min)	650	650	650	400	400	400
		<i>vf</i> (mm/min)	9,330	7,470	6,220	9,560	7,650	6,380
		<i>fz</i> (mm/t)	0.3	0.3	0.3	0.5	0.5	0.5
		<i>ap</i> (mm)	0.1	0.1	0.1	0.5	0.5	0.5
		<i>ae</i> (mm)	Refer below table			Refer below table		
Hardened steels (45~55HRC)	TH315	<i>n</i> (min ⁻¹)	3,990	3,190	2,660	1,920	1,530	1,280
		<i>vc</i> (m/min)	250	250	250	120	120	120
		<i>vf</i> (mm/min)	2,400	1,920	1,600	580	460	390
		<i>fz</i> (mm/t)	0.2	0.2	0.2	0.15	0.15	0.15
		<i>ap</i> (mm)	0.08	0.08	0.08	0.2	0.2	0.2
		<i>ae</i> (mm)	Refer below table			Refer below table		

How to calculate "ae"

Determine the *ae* value based on the desired cusp height by selecting it from the table below or by calculating it using the equation below.

Insert	R	Cusp height (mm)						
		0.001	0.002	0.003	0.004	0.005	0.01	0.02
TPHW0902-20	20	0.4	0.57	0.69	0.8	0.89	1.26	1.79
TPHW1303-25	25	0.45	0.63	0.77	0.89	1	1.41	2
TPHW1403-30	30	0.49	0.69	0.85	0.98	1.1	1.55	2.19

$$ae = 2 \sqrt{(R^2 - (R - H)^2)}$$

R: Tool R H: Cusp height

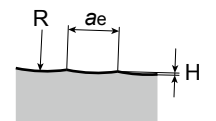

- [Note]**
- ① Use the appropriate coolant for the work material and machining shape.
 - ② These conditions are for general guidance; in actual machining conditions adjust the parameters according to your actual machine and work-piece conditions.
 - ③ To prevent tool breakage due to chips clogging tool flutes, always be sure to use an air blower, etc. to remove chips.
 - ④ Ensure to index the insert at the correct time to ensure safety of the tool-body.

Adjustment ratio of cutting conditions by overhang length.

When overhang length is 3*Dc* or more, please adjust the values in the above cutting condition table referring to the right table.

Overhang ratio	Vc (m/min)	Vf (mm/min)
<3 <i>Dc</i>	100%	100%
3 <i>Dc</i> ~ 5 <i>Dc</i>	70%	70%
5 <i>Dc</i> ~ 6 <i>Dc</i>	60%	60%
6 <i>Dc</i> ~ 7 <i>Dc</i>	50%	50%
7 <i>Dc</i> ~	45%	45%

GF1

GF2T

GF3L

GP1LB

GP1T

GS4TN

Modular type

GP1LB \circ \square M-M \circ

Numeric figure in a circle \circ and Alphabetical character comes in a square \square

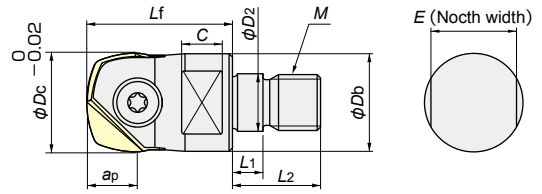

Item code	Stock	No. of Inserts	Size (mm)										Insert
			ϕDc	Lf	a_p	$\phi D2$	M	ϕDb	$L1$	$L2$	C	E	
GP1LB16M-M8	●	1	16	32	8	8.5	M8	12.8	5.5	17	8	10	ZPHW160-LB16
GP1LB20M-M10	●	1	20	38	10	10.5	M10	17.8	5.5	19	10	15	ZPHW200-LB20
GP1LB25M-M12	●	1	25	38	12.5	12.5	M12	20.8	5.5	22	10	17	ZPHW250-LB25
GP1LB30M-M16	●	1	30	43	15	17	M16	28.8	6	23	12	22	ZPHW300-LB30

[Note] Do not apply lubricants such as grease, etc. to the "contact faces" and "modular screws" of the "modular mill", "special shanks" and "special arbor".
 ※For information on the detailed tool shape, download the DXF data from the MOLDINO Tool Engineering home page. (MOLDINO Tool Engineering tool selection database TOOL SEARCH: <http://data.moldino.com/toolsearch/?lang=en>)

Inserts

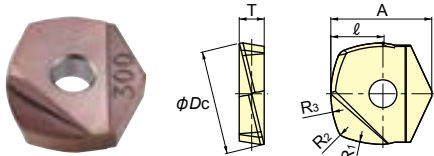

Material	Grade	General cutting	First recommended
P Carbon steels, Alloy steels	PM215	■	□
M SUS, etc.	TH308	■	□
K FC + FCD		■	□
H Hardened steels		■	□

■ : General cutting, First recommended
 □ : General cutting, Second recommended

Item code	Tolerance class	Grade		Size (mm)						
		PM215	TH308	R_1	R_2	R_3	l	A	ϕDc	T
ZPHW160-LB16	H	●	●	16	1.5	16	8	16.6	16	4.2
ZPHW160-LB16-R5	H	●	●	16	5	16	8	16.6	16	4.2
ZPHW200-LB20	H	●	●	20	1.9	20	10	20.3	20	5.2
ZPHW200-LB20-R6	H	●	●	20	6	20	10	20.3	20	5.2
ZPHW250-LB25	H	●	●	25	2.38	25	12.5	24.1	25	6.2
ZPHW250-LB25-R8	H	●	●	25	8	25	12.5	24.1	25	6.2
ZPHW300-LB30	H	●	●	30	2.85	30	15	29.1	30	7.2
ZPHW300-LB30-R10	H	●	●	30	10	30	15	29.1	30	7.2

[Note] The numbers after the third decimal point are rounded off. When defining the shape parametrically, check the required dimensions from the DXF data.

Insert of GP1LB, regrinding can be performed up to a maximum of 2 times.

Please inquire insert re-grinding / re-coating to sales office.

Parts

To reduce environmental loads, drivers and screw anti-seizure agent are sold separately.
 We ask for your understanding and cooperation.

Parts	Clamp screw	Not included with product (sold separately)	
		Wrench	Screw anti-seizure agent
Shape			
Cutter body	Fastening torque (N·m)		
GP1LB16M-M8	581-144 4.9	105-T20	P-37
GP1LB20M-M10	581-145 6.9	101-T25S	
GP1LB25M-M12	581-146 9.8	105-T30A	
GP1LB30M-M16	581-147 9.8		

※The insert can be attached to Ball Precision F (ABPF type) holders.
 ※For information on the detailed tool shape, download the DXF data from the MOLDINO Tool Engineering home page. (MOLDINO Tool Engineering tool selection database TOOL SEARCH: <http://data.moldino.com/toolsearch/?lang=en>)

How to select GP1LB inserts

Comparison of cutting efficiency of 3-axis machining with $\phi 30$ tool. ※Set the cusp-height of each edge of barrel R, lens R and corner-connected R same as ball end mill

Ball end mill ($\phi 30$)



Ball end mill is recommended for shapes with large undulations

GP1LB ZPHW300-LB30-R10

1.4 times cutting efficiency than ball end mill

Cutting efficiency Compared with the ball end mill 0.8 times



High efficiency machining on undulating curved surface.

If the barrel R and lens R can be used more than 47% of the whole machining, more efficient than ball end mill of same diameter.

GP1LB ZPHW300-LB30

1.4 times cutting efficiency than ball end mill

Cutting efficiency Compared with the ball end mill 0.4 times



High efficiency machining with gentle curved surface with less undulation.

If the barrel R and lens R can be used more than 84% of the whole machining, more efficient than ball end mill of same diameter.

※Checking the usage rate of barrel R edge and lens R edge in model shape to be processed and choosing an insert, possible more efficient machining.

★: Stocked Items of New Products. ●: Stocked Items.

Recommended cutting conditions

*Red indicates primary recommended grade.

Work material	Recommended grade	Cutting condition	Lens part				Barrel part			
			φ16	φ20	φ25	φ30	φ16	φ20	φ25	φ30
Carbon steels Alloy steels (<30HRC)	PN215	<i>n</i> (min ⁻¹)	14,340	11,470	9,180	7,650	11,950	9,560	7,650	6,370
		<i>vc</i> (m/min)	720	720	720	720	600	600	600	600
		<i>vf</i> (mm/min)	7,170	5,740	4,590	3,830	4,780	3,830	3,060	2,550
		<i>fz</i> (mm/t)	0.25	0.25	0.25	0.25	0.2	0.2	0.2	0.2
		<i>ap</i> (mm)	0.1	0.1	0.1	0.1	Refer below table			
		<i>ae</i> (mm)	Refer below table				0.1	0.1	0.1	0.1
Carbon steels Alloy steels (30~45HRC)	PN215 TH308	<i>n</i> (min ⁻¹)	10,360	8,290	6,630	5,530	7,970	6,370	5,100	4,250
		<i>vc</i> (m/min)	520	520	520	520	400	400	400	400
		<i>vf</i> (mm/min)	5,180	4,150	3,320	2,770	3,190	2,550	2,040	1,700
		<i>fz</i> (mm/t)	0.25	0.25	0.25	0.25	0.2	0.2	0.2	0.2
		<i>ap</i> (mm)	0.1	0.1	0.1	0.1	Refer below table			
		<i>ae</i> (mm)	Refer below table				0.1	0.1	0.1	0.1
Stainless steels SUS	PN215	<i>n</i> (min ⁻¹)	12,940	10,360	8,290	6,910	9,960	7,970	6,370	5,310
		<i>vc</i> (m/min)	650	650	650	650	500	500	500	500
		<i>vf</i> (mm/min)	6,470	5,180	4,150	3,460	3,990	3,190	2,550	2,130
		<i>fz</i> (mm/t)	0.25	0.25	0.25	0.25	0.2	0.2	0.2	0.2
		<i>ap</i> (mm)	0.1	0.1	0.1	0.1	Refer below table			
		<i>ae</i> (mm)	Refer below table				0.1	0.1	0.1	0.1
Cast iron FC FCD	TH308 PN215	<i>n</i> (min ⁻¹)	14,340	11,470	9,180	7,650	11,950	9,560	7,650	6,370
		<i>vc</i> (m/min)	720	720	720	720	600	600	600	600
		<i>vf</i> (mm/min)	11,480	9,180	7,350	6,120	5,980	4,780	3,830	3,190
		<i>fz</i> (mm/t)	0.4	0.4	0.4	0.4	0.25	0.25	0.25	0.25
		<i>ap</i> (mm)	0.1	0.1	0.1	0.1	Refer below table			
		<i>ae</i> (mm)	Refer below table				0.1	0.1	0.1	0.1
Hardened steels (45~55HRC)	TH308	<i>n</i> (min ⁻¹)	6,370	5,100	4,080	3,400	4,980	3,990	3,190	2,660
		<i>vc</i> (m/min)	320	320	320	320	250	250	250	250
		<i>vf</i> (mm/min)	2,550	2,040	1,640	1,360	1,500	1,200	960	800
		<i>fz</i> (mm/t)	0.20	0.20	0.20	0.20	0.15	0.15	0.15	0.15
		<i>ap</i> (mm)	0.08	0.08	0.08	0.08	Refer below table			
		<i>ae</i> (mm)	Refer below table				0.08	0.08	0.08	0.08
Hardened steels (55~62HRC)	TH308	<i>n</i> (min ⁻¹)	5,580	4,460	3,570	2,980	4,380	3,510	2,810	2,340
		<i>vc</i> (m/min)	280	280	280	280	220	220	220	220
		<i>vf</i> (mm/min)	2,240	1,790	1,430	1,200	1,320	1,060	850	710
		<i>fz</i> (mm/t)	0.20	0.20	0.20	0.20	0.15	0.15	0.15	0.15
		<i>ap</i> (mm)	0.05	0.05	0.05	0.05	Refer below table			
		<i>ae</i> (mm)	Refer below table				0.05	0.05	0.05	0.05

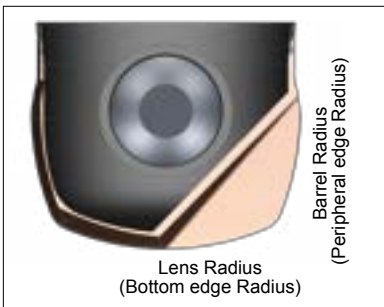

- For machining shapes that make heavy use of lens R, refer to the "Lens part cutting conditions" in the above table.
- For machining shapes that make heavy use of barrel R, refer to the "Barrel part cutting conditions" in the above table.
- For machining shapes that use both lens R and barrel R equally, refer to the conditions with the higher usage ratio.

When overhang length is 3Dc or greater, adjust the values shown in the below table according to the above table.

Overhang ratio	Vc (m/min)	Vf (mm/min)
<3Dc	100%	100%
3Dc ~ 5Dc	70%	70%
5Dc ~ 6Dc	60%	60%
6Dc ~ 7Dc	50%	50%
7Dc ~	45%	45%

Determine the *ap* or *ae* value based on the desired cusp height by selecting it from the table below or by calculating it using the equation below.

Insert		Cusp height (mm)					
Item code	R	0.001	0.002	0.003	0.004	0.005	0.01
ZPHW160-LB16	16	0.36	0.51	0.62	0.72	0.8	1.13
ZPHW200-LB20	20	0.4	0.57	0.69	0.8	0.89	1.26
ZPHW250-LB25	25	0.45	0.63	0.77	0.89	1	1.41
ZPHW300-LB30	30	0.49	0.69	0.85	0.98	1.1	1.55

$$a_p = 2 \sqrt{(R^2 - (R - H)^2)}$$

(*ae*)

R : Tool R H : Cusp height

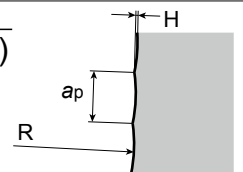

- [Note]**
- ① Use the appropriate coolant for the work material and machining shape.
 - ② These conditions are for general guidance; in actual machining conditions adjust the parameters according to your actual machine and work-piece conditions.
 - ③ To prevent tool breakage due to chips clogging tool flutes, always be sure to use an air blower, etc. to remove chips.
 - ④ Ensure to index the insert at the correct time to ensure safety of the tool-body.

Refer page 15 for set-up procedures of inserts.

GF1

GF21

GF3L

GP1LB

GP1T

GS4TN

Modular type

GP1T \circ \square M-M \circ

Numeric figure in a circle \circ and Alphabetical character comes in a square \square

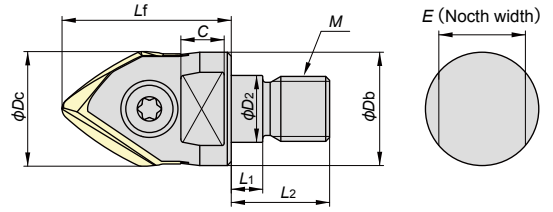

Item code	Stock	No. of flutes	Size (mm)									Insert
			ϕDc	Lf	$\phi D2$	M	ϕDb	$L1$	$L2$	C	E	
GP1T12M-M6	●	1	12	26	6.5	M6	9.8	5.5	14.5	5	7	ZDHW120-T43R1.2-30
GP1T16M-M8	●	1	16	32	8.5	M8	12.8	5.5	17	8	10	ZDHW160-T43R1.6-40
GP1T20M-M10	●	1	20	38	10.5	M10	17.8	5.5	19	10	15	ZDHW200-T43R2-50
GP1T25M-M12	●	1	25	38	12.5	M12	20.8	5.5	22	9	17	ZDHW250-T43R2.5-62.5
GP1T30M-M16	●	1	30	43	17	M16	28.8	6	23	11	22	ZDHW300-T43R3-75

[Note] Do not apply lubricants such as grease, etc. to the "contact faces" and "modular screws" of the "modular mill", "special shanks" and "special arbor".
 ※ For information on the detailed tool shape, download the DXF data from the MOLDINO Tool Engineering home page.
 (MOLDINO Tool Engineering tool selection database TOOL SEARCH: <http://data.moldino.com/toolsearch/?lang=en>)

Inserts

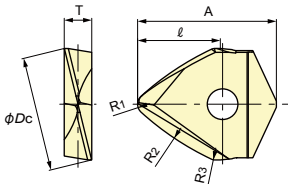

R accuracy : ± 0.01 (Insert itself)

Item code	Tolerance class	Grade		Size(mm)						
		PN215	TH308	R1	R2	R3	ℓ	A	ϕDc	T
ZDHW120-T43R1.2-30	H	●	●	1.2	30	0.98	8.6	17.6	12	3.2
ZDHW160-T43R1.6-40		●	●	1.6	40	1.3	11.3	20.6	16	4.2
ZDHW200-T43R2-50		●	●	2.0	50	1.63	14.3	25.4	20	5.2
ZDHW250-T43R2.5-62.5		●	●	2.5	62.5	2.04	17.9	30.1	25	6.2
ZDHW300-T43R3-75		●	●	3.0	75	2.45	21.6	36.3	30	7.2

- P** Carbon steels, Alloy steels
- M** SUS, etc.
- K** FC · FCD
- H** Hardened steels

- : General cutting, First recommended
- : General cutting, Second recommended

• The insert can be set with "ABPF-type" cutter body • Use solid barrel end mill, "GS4TN-type" for smaller diameter in size
[Note] The numbers after the third decimal point are rounded off. When defining the shape parametrically, check the required dimensions from the DXF data.
 ※ For information on the detailed tool shape, download the DXF data from the MOLDINO Tool Engineering home page.
 (MOLDINO Tool Engineering tool selection database TOOL SEARCH: <http://data.moldino.com/toolsearch/?lang=en>)

Parts

To reduce environmental loads, drivers and screw anti-seizure agent are sold separately.
 We ask for your understanding and cooperation.

Parts	Clamp screw	Not included with product (sold separately)	
		Wrench	Screw anti-seizure agent
Shape			
Cutter body	Fastening torque (N·m)		
GP1T12M-M6	581-143	4.9	P-37
GP1T16M-M8	581-144	4.9	
GP1T20M-M10	581-145	6.9	
GP1T25M-M12	581-146	9.8	
GP1T30M-M16	581-147	9.8	

Angle range of barrel R and tip R

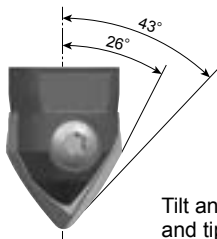

Tilt angle range of barrel R and tip R

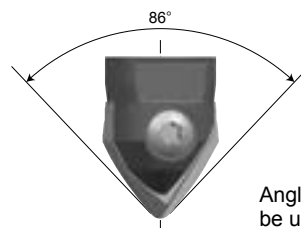

Angle range of tip R that can be used as a ball end mill

● : Stocked Items.

Recommended cutting conditions

※Red indicates primary recommended grade.

Work material	Recommended grade	Cutting conditions	Tip R					Barrel R				
			φ12(R1.2)	φ16(R1.6)	φ20(R2)	φ25(R2.5)	φ30(R3)	φ12	φ16	φ20	φ25	φ30
Carbon steels Alloy steels (<30HRC)	PN215	<i>n</i> (min ⁻¹)	19,910	14,930	11,950	9,560	7,970	19,110	14,340	11,470	9,180	7,650
		<i>vc</i> (m/min)	750(150)	750(150)	750(150)	750(150)	750(150)	720	720	720	720	720
		<i>vf</i> (mm/min)	1,600	1,500	1,440	1,340	1,280	5,740	4,310	3,450	2,760	2,300
		<i>fz</i> (mm/t)	0.04	0.05	0.06	0.07	0.08	0.15	0.15	0.15	0.15	0.15
		<i>ap</i> (mm)	0.1	0.1	0.1	0.1	0.1	Refer to the below table				
		<i>ae</i> (mm)	Refer to the below table					0.1	0.1	0.1	0.1	0.1
Carbon steels Alloy steels (30~45HRC)	PN215 TH308	<i>n</i> (min ⁻¹)	18,580	13,940	11,150	8,920	7,440	13,810	10,360	8,290	6,630	5,530
		<i>vc</i> (m/min)	700(140)	700(140)	700(140)	700(140)	700(140)	520	520	520	520	520
		<i>vf</i> (mm/min)	1,490	1,400	1,340	1,250	1,200	4,150	3,110	2,490	1,990	1,660
		<i>fz</i> (mm/t)	0.04	0.05	0.06	0.07	0.08	0.15	0.15	0.15	0.15	0.15
		<i>ap</i> (mm)	0.1	0.1	0.1	0.1	0.1	Refer to the below table				
		<i>ae</i> (mm)	Refer to the below table					0.1	0.1	0.1	0.1	0.1
Stainless steels SUS	PN215	<i>n</i> (min ⁻¹)	19,910	14,930	11,950	9,560	7,970	17,260	12,940	10,360	8,290	6,910
		<i>vc</i> (m/min)	750(150)	750(150)	750(150)	750(150)	750(150)	650	650	650	650	650
		<i>vf</i> (mm/min)	1,600	1,500	1,440	1,340	1,280	5,180	3,890	3,110	2,490	2,080
		<i>fz</i> (mm/t)	0.04	0.05	0.06	0.07	0.08	0.15	0.15	0.15	0.15	0.15
		<i>ap</i> (mm)	0.1	0.1	0.1	0.1	0.1	Refer to the below table				
		<i>ae</i> (mm)	Refer to the below table					0.1	0.1	0.1	0.1	0.1
Cast iron FC FCD	TH308 PN215	<i>n</i> (min ⁻¹)	19,910	14,930	11,950	9,560	7,970	19,110	14,340	11,470	9,180	7,650
		<i>vc</i> (m/min)	750(150)	750(150)	750(150)	750(150)	750(150)	720	720	720	720	720
		<i>vf</i> (mm/min)	1,600	1,500	1,440	1,340	1,280	7,650	5,740	4,590	3,680	3,060
		<i>fz</i> (mm/t)	0.04	0.05	0.06	0.07	0.08	0.2	0.2	0.2	0.2	0.2
		<i>ap</i> (mm)	0.1	0.1	0.1	0.1	0.1	Refer to the below table				
		<i>ae</i> (mm)	Refer to the below table					0.1	0.1	0.1	0.1	0.1
Hardened steels (45~55HRC)	TH308	<i>n</i> (min ⁻¹)	13,270	9,960	7,970	6,370	5,310	8,500	6,370	5,100	4,080	3,400
		<i>vc</i> (m/min)	500(100)	500(100)	500(100)	500(100)	500(100)	320	320	320	320	320
		<i>vf</i> (mm/min)	1,070	1,000	960	900	850	1,700	1,280	1,020	820	680
		<i>fz</i> (mm/t)	0.04	0.05	0.06	0.07	0.08	0.1	0.1	0.1	0.1	0.1
		<i>ap</i> (mm)	0.08	0.08	0.08	0.08	0.08	Refer to the below table				
		<i>ae</i> (mm)	Refer to the below table					0.08	0.08	0.08	0.08	0.08
Hardened steels (55~62HRC)	TH308	<i>n</i> (min ⁻¹)	11,950	8,960	7,170	5,740	4,780	7,440	5,580	4,460	3,570	2,980
		<i>vc</i> (m/min)	450(90)	450(90)	450(90)	450(90)	450(90)	280	280	280	280	280
		<i>vf</i> (mm/min)	960	900	870	810	770	1,490	1,120	900	720	600
		<i>fz</i> (mm/t)	0.04	0.05	0.06	0.07	0.08	0.1	0.1	0.1	0.1	0.1
		<i>ap</i> (mm)	0.05	0.05	0.05	0.05	0.05	Refer to the below table				
		<i>ae</i> (mm)	Refer to the below table					0.05	0.05	0.05	0.05	0.05

※The () values of *vc* indicate the cutting speed of the tip R part.

When overhang length is 3Dc or greater, adjust the values shown in the table at right according to the above table.

Overhang ratio	Vc (m/min)	Vf (mm/min)
<3Dc	100%	100%
3Dc ~ 5Dc	70%	70%
5Dc ~ 6Dc	60%	60%

Overhang ratio	Vc (m/min)	Vf (mm/min)
6Dc ~ 7Dc	50%	50%
7Dc ~	45%	45%

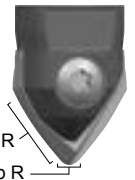

Determine the *ap* or *ae* value based on the desired cusp height by selecting it from the table below or by calculating it using the equation below.

Insert Item code	Cutting depth using barrel R <i>ap</i> (mm)							Cutting depth using tip R <i>ae</i> (mm)								
	Barrel R	Cusp height (mm)							Tip R	Cusp height (mm)						
		0.0005	0.001	0.002	0.003	0.004	0.005	0.01		0.0005	0.001	0.002	0.003	0.004	0.005	0.01
ZDHW120-T43R1.2-30	30	0.35	0.49	0.69	0.85	0.98	1.1	1.55	1.2	0.07	0.1	0.14	0.17	0.2	0.22	0.31
ZDHW160-T43R1.6-40	40	0.4	0.57	0.8	0.98	1.13	1.26	1.79	1.6	0.08	0.11	0.16	0.2	0.23	0.25	0.36
ZDHW200-T43R2-50	50	0.45	0.63	0.89	1.1	1.26	1.41	2	2	0.09	0.13	0.18	0.22	0.25	0.28	0.4
ZDHW250-T43R2.5-62.5	62.5	0.5	0.71	1	1.22	1.41	1.58	2.24	2.5	0.1	0.14	0.2	0.24	0.28	0.32	0.45
ZDHW300-T43R3-75	75	0.55	0.77	1.1	1.34	1.55	1.73	2.45	3	0.11	0.15	0.22	0.27	0.31	0.35	0.49

$$a_p = 2 \sqrt{(R^2 - (R-H)^2)} \quad (ae)$$

R: Tool R H: Cusp height

- [Note]**
- ① Use the appropriate coolant for the work material and machining shape.
 - ② These conditions are for general guidance; in actual machining conditions adjust the parameters according to your actual machine and work-piece conditions.
 - ③ To prevent tool breakage due to chips clogging tool flutes, always be sure to use an air blower, etc. to remove chips.
 - ④ Ensure to index the insert at the correct time to ensure safety of the tool-body.

Set-up Procedures of Inserts

1 Clean the insert seat:
Using air-blow or alike, clean the seat.

2 Put in the insert with its top positioned to the screw-tightening side of the tool body.

3 Tighten the clamp screw with the special wrench. Please do not press down the insert during this tightening process.

4 This is the end of insert set-up.

Clamp screw (high precision screw)

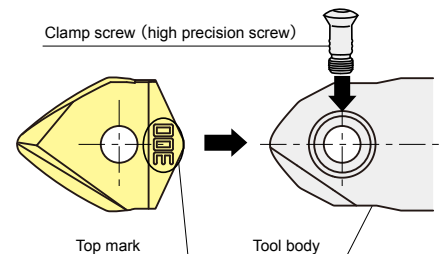

Attention

Never tighten the clamp screw without putting the insert. The tool body may be deformed, resulting in improper insert mounting or deterioration of mounting accuracy.



Do not tighten the screw without putting insert

GF1

GF2T

GF3L

GP1LB

GP1T

GS4TN

Modular Shank

Carbide Shank

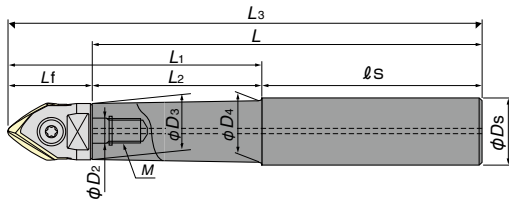

Type A

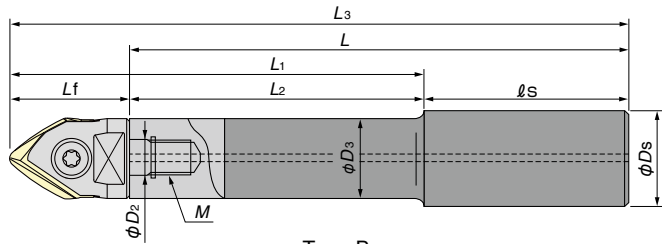

Type B

Item Code	Stock	Size (mm)											Type	Cutter body
		φD ₂	M	L ₃	L	L _f	L ₂	L ₁	ℓ _s	φD ₃	φD _s	φD ₄		
ASC12-6.5-74-24Z	●	6.5	M6	(100)	74	(26)	24	(50)	50	11	12	11.5	A	GP1T12M-M6
ASC12-6.5-94-44Z	●			(120)	94		44	(70)	50					
ASC12-6.5-129-64Z	●			(155)	129		64	(90)	65					
ASC12-6.5-129-24Z	●			(155)	129		24	(50)	105					
ASC16-8.5-95-30Z	●	8.5	M8	120(127)	95	25(32)	30	55 (62)	65	14.5	16	15.5	A	GF1G2016M-2-M8 GF1T2016M-2-M8 GP1LB16M-M8 GP1T16M-M8
ASC16-8.5-120-55Z	●			145(152)	120		55	80 (87)	65					
ASC16-8.5-140-75Z	●			165(172)	140		75	100(107)	65					
ASC16-8.5-160-95Z	●			185(192)	160		95	120(127)	65					
ASC16-8.5-160-30Z	●			185(192)	160		30	55 (62)	130					
ASC20-10.5-120-50Z	●	10.5	M10	150(158)	120	30(38)	50	80 (88)	70	18.5	20	19.5	A	GF1G2020M-3-M10 GF1T2020M-3-M10 GF1G2025M-4-M10 GF2T3020M-3 GF3L20M-3-M10 GP1LB20M-M10 GP1T20M-M10
ASC20-10.5-170-90Z	●			200(208)	170		90	120(128)	80					
ASC20-10.5-220-120Z	●			250(258)	220		120	150(158)	100					
ASC20-10.5-270-150Z	●			300(308)	270		150	180(188)	120					
※2 ASC20-10.5-220-50Z	●	10.5	M10	250(258)	220	30(38)	50	80 (88)	170	18.5	20	19.5	A	
※2 ASC20-10.5-270-50Z	●	300(308)	270						220					
ASC25-12.5-145-65	●	12.5	M12	180(183)	145	35(38)	65	100(103)	80	23	25	-	B	GF1G2025M-4-M12 GF1T2025M-4-M12 GF2T3025M-4 GF3L25M-3-M12 GP1LB25M-M12 GP1T25M-M12
ASC25-12.5-215-115	●			250(253)	215		115	150(153)	100					
ASC25-12.5-265-145	●			300(303)	265		145	180(183)	120					
ASC25-12.5-315-195	●			350(353)	315		195	230(233)	120					
ASC25-12.5-265-65	●	12.5	M12	300(303)	265	35(38)	65	100(103)	200	23	25	-	B	
ASC25-12.5-315-65	●	350(353)	315						250					
ASC32-17-160-80	●	17	M16	200(203)	160	40(43)	80	120(123)	80	28	32	-	B	GF2T3035M-5 GF2T3040M-6 GF3L30M-3-M16 GP1T30M-M16 GP1LB30M-M16
ASC32-17-210-110	●			250(253)	210		110	150(153)	100					
ASC32-17-260-140	●			300(303)	260		140	180(183)	120					
ASC32-17-310-190	●			350(353)	310		190	230(233)	120					
ASC32-17-360-240	●			400(403)	360		240	280(283)	120					
※2 ASC32-17-260-80	●			300(303)	260				180					
※2 ASC32-17-310-80	●	350(353)	310	40(43)	80	120(123)	230	28	32	-	B			
※2 ASC32-17-360-80	●	400(403)	360			280								

- When※2 and ※1 (pp.6,8) are used together as a set, there is no interference.
- Dimensions in () are when GP1LB or GP1T is attached.
- Other shanks for modular mill, arbor can also be used. Please refer to pages D6 to D15 of the total catalog 2019-2020.
- Use steel shank for short projection application.

Steel Shank

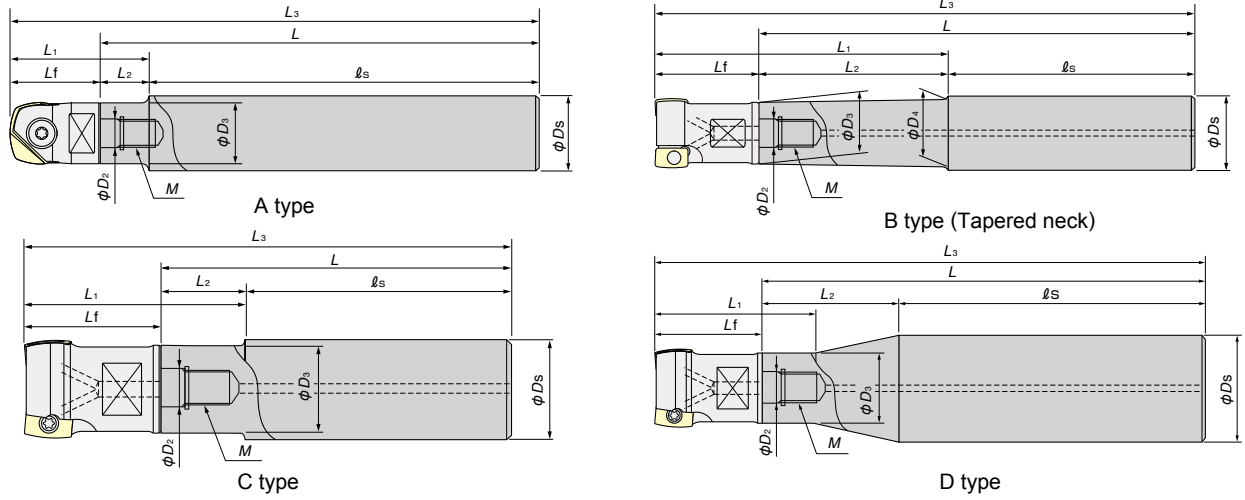

Item Code	Stock	Size(mm)											Shape	Cutter body
		ϕD_2	M	L_3	L	L_f	L_2	L_1	l_s	ϕD_3	ϕD_4	ϕD_s		
AS12-6.5-84-4	●	6.5	M6	104(110)	84	20(26)	4	24(30)	80	11	12	-	A	GP1T12M-M6
AS16-8.5-95-15	●	8.5	M8	120(127)	95	25(32)	15	40(47)	80	14.5	16	15.5	B	GF1G2016M-2-M8 GF1T2016M-2-M8 GP1LB16M-M8 GP1T16M-M8
AS20-10.5-100-20	●	10.5	M10	130(138)	100	30(38)	20	50(58)	80	18	20	-	C	GF1G2020M-3-M10 GF1T2020M-3-M10 GF1G2025M-4-M10 GF2T3020M-3 GF3L20M-3-M10 GP1LB20M-M10 GP1T20M-M10
AS25-12.5-115-35	●	12.5	M12	150(153)	115	35(38)	35	70(73)	80	23	25	-	C	GF1G2025M-4-M12 GF1T2025M-4-M12 GF2T3025M-4 GF3L25M-3-M12 GP1LB25M-M12 GP1T25M-M12
AS32-17-110-30	●	17	M16	150(153)	110	40(43)	30	70(73)	80	28	32	-	C	GF2T3035M-5 GF2T3040M-6 GF3L30M-3-M16 GP1T30M-M16 GP1LB30M-M16
AS42-17-360-90	●	17	M16	400(403)	360	40(43)	90	67(70)	270	28	42	-	D	GF2T3035M-5 GF2T3040M-6 GF3L30M-3-M16 GP1T30M-M16 GP1LB30M-M16

- Commercial milling chucks can be used.
- Dimensions in () are when GP1LB or GP1T is attached.
- For AS42-17-360-90 neck section or total length, additional machining to user specifications is possible.

GP1LB and GP1T inserts can be set in ABPF cutter body.

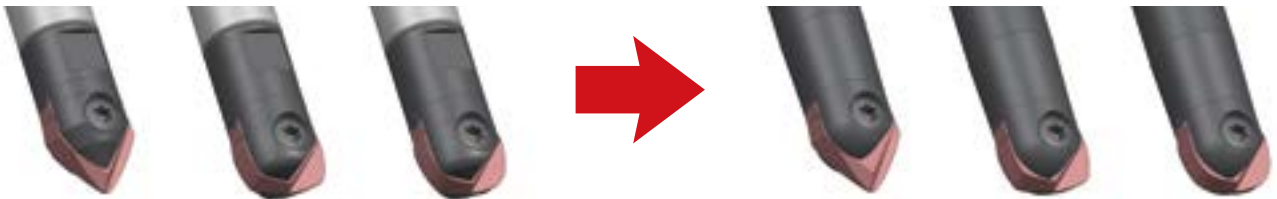

Set to original cutter body

Can be set in ABPF cutter body

The insert of GP1LB and GP1T are able to set in ABPF cutter body.
Please check "Multi purpose usage list of ABPF type cutter body" (No.1708)

Solid type

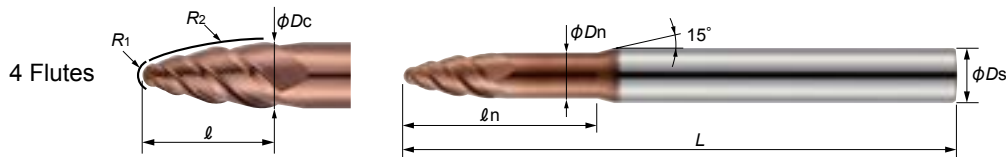

GS4TN $\phi\phi\phi\phi$ - $\phi\phi\phi\phi$ R-TH3



Form tolerance : ±0.01

Item code	Stock	Size (mm)							
		Tip R R ₁	Barrel R R ₂	Tool dia. D _c	Flute length ℓ	Under neck length ℓ _n	Neck dia. D _n	Overall length L	Shank dia. D _s
GS4TN2.5-12.5R-TH3	◎	0.5	12.5	2.5	4.68	10	2.4	50	4
GS4TN3.75-18.75R-TH3	◎	0.75	18.75	3.75	7.01	15	3.65	50	4
GS4TN5-25R-TH3	◎	1	25	5	9.35	20	4.8	60	6
GS4TN7.5-37.5R-TH3	◎	1.5	37.5	7.5	14.03	30	7.3	75	8
GS4TN10-50R-TH3	◎	2	50	10	18.70	40	9.5	100	12

- There is no regrinding compatibility for this tool.
- For the large diameter end mill "GP1T".

※For information on the detailed tool shape, download the DXF data from the MOLDINO Tool Engineering home page.
(MOLDINO Tool Engineering tool selection database TOOL SEARCH: <http://data.moldino.com/toolsearch/?lang=en>)

Machining method of GS4TN

When using with 5-axis machine

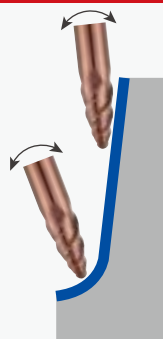

By using the barrel R with tilted tool axis, tilted section can be cut with large pitch. Furthermore, it is possible to cut with less machining steps by using the tip R.

Processable with GS4TN

When using with 3-axis machine



Barrel R enables to cut steep face with large pitch. However, it is necessary to process the bottom corner section with a separate tool.

Needs separate tool

High helix shape realized low cutting force

Cutting conditions

Work material : YXR33(58HRC)

Tool : GS4TN10-50R-TH3

2 flutes Ball End Mill

Shape : See the figure right

Condition :

$n=4780\text{min}^{-1}$

$v_f=956\text{mm/min}$

(Ball : $v_f=478$)

$a_p=0.5\text{mm}$ $a_e=0.3\text{mm}$

Contouring

Down cut

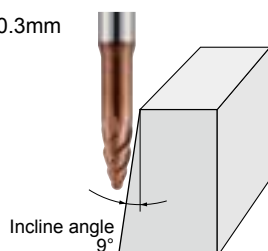

GS4TN

2 flutes Ball End mill

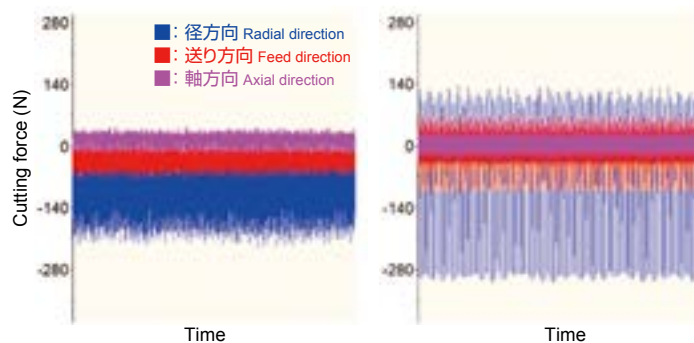

High helix shape reduces cutting force, 4 flutes improve efficiency

◎ : manufacturer stocked items. Contact with our sales office.

Recommended cutting conditions

● Barrel R cutting condition

Work material		Carbon steel, Alloy steel (<35HRC)				Pre-hardened steel (35~45HRC)				Hardened steel (45~55HRC)				Hardened steel (55~65HRC)				Hardened steel (65~72HRC)			
Tip R R1 (mm)	Barrel R R2 (mm)	Revolution n min ⁻¹	Feed rate vf mm/min	ap mm	ae mm	Revolution n min ⁻¹	Feed rate vf mm/min	ap mm	ae mm	Revolution n min ⁻¹	Feed rate vf mm/min	ap mm	ae mm	Revolution n min ⁻¹	Feed rate vf mm/min	ap mm	ae mm	Revolution n min ⁻¹	Feed rate vf mm/min	ap mm	ae mm
0.5	12.5	23,550	3,060	0.22	0.05~0.1	19,100	2,480	0.22	0.05~0.1	17,830	1,960	0.22	0.05~0.1	16,550	1,820	0.22	0.01~0.05	12,730	1,400	0.22	0.01~0.05
0.75	18.75	15,700	2,670	0.27	0.05~0.1	13,840	2,460	0.27	0.05~0.1	11,880	1,780	0.27	0.05~0.1	11,370	1,640	0.27	0.01~0.05	8,570	1,230	0.27	0.01~0.05
1	25	11,780	2,540	0.32	0.05~0.1	10,500	2,260	0.32	0.05~0.1	9,130	1,670	0.32	0.05~0.1	7,040	1,440	0.32	0.01~0.05	6,490	1,100	0.32	0.01~0.05
1.5	37.5	7,850	1,990	0.39	0.05~0.1	6,930	1,780	0.39	0.05~0.1	6,190	1,390	0.39	0.05~0.1	4,460	1,230	0.39	0.01~0.05	4,290	920	0.39	0.01~0.05
2	50	5,890	1,680	0.45	0.05~0.1	5,100	1,460	0.45	0.05~0.1	4,510	1,130	0.45	0.05~0.1	3,520	1,000	0.45	0.01~0.05	3,190	770	0.45	0.01~0.05

● Tip R cutting condition

Work material		Carbon steel, Alloy steel (<35HRC)				Pre-hardened steel (35~45HRC)				Hardened steel (45~55HRC)				Hardened steel (55~65HRC)				Hardened steel (65~72HRC)			
Tip R R1 (mm)	Barrel R R2 (mm)	Revolution n min ⁻¹	Feed rate vf mm/min	ap mm	ae mm	Revolution n min ⁻¹	Feed rate vf mm/min	ap mm	ae mm	Revolution n min ⁻¹	Feed rate vf mm/min	ap mm	ae mm	Revolution n min ⁻¹	Feed rate vf mm/min	ap mm	ae mm	Revolution n min ⁻¹	Feed rate vf mm/min	ap mm	ae mm
0.5	12.5	34,320	2,580	0.09	0.29	28,600	2,060	0.08	0.24	26,000	1,870	0.06	0.18	24,700	1,600	0.06	0.18	20,800	1,120	0.05	0.15
0.75	18.75	25,680	2,890	0.10	0.31	21,400	2,310	0.09	0.26	19,500	2,110	0.07	0.21	18,500	1,800	0.07	0.21	15,600	1,260	0.06	0.18
1	25	22,080	3,310	0.19	0.58	18,400	2,650	0.16	0.48	16,700	2,400	0.13	0.39	15,900	2,060	0.12	0.36	13,400	1,450	0.10	0.30
1.5	37.5	20,400	3,280	0.28	0.86	17,000	2,620	0.24	0.72	15,400	1,850	0.20	0.60	14,300	1,720	0.19	0.57	11,000	1,320	0.15	0.45
2	50	15,600	3,040	0.38	1.15	13,000	2,430	0.32	0.96	11,000	1,760	0.27	0.81	10,560	1,580	0.25	0.75	7,920	1,190	0.20	0.60

● Cutting condition for using both barrel R and tip R

Work material		Carbon steel, Alloy steel (<35HRC)		Pre-hardened steel (35~45HRC)		Hardened steel (45~55HRC)		Hardened steel (55~65HRC)		Hardened steel (65~72HRC)	
Tip R R1 (mm)	Barrel R R2 (mm)	Revolution n min ⁻¹	Feed rate vf mm/min	Revolution n min ⁻¹	Feed rate vf mm/min	Revolution n min ⁻¹	Feed rate vf mm/min	Revolution n min ⁻¹	Feed rate vf mm/min	Revolution n min ⁻¹	Feed rate vf mm/min
0.5	12.5	28,940	2,820	23,850	2,270	21,920	1,920	20,630	1,710	16,770	1,260
0.75	18.75	20,690	2,780	17,620	2,390	15,690	1,950	14,940	1,720	12,090	1,250
1	25	16,930	2,930	14,450	2,460	12,920	2,040	11,470	1,750	9,950	1,280
1.5	37.5	14,130	2,640	11,970	2,200	10,800	1,620	9,380	1,480	7,650	1,120
2	50	10,750	2,360	9,050	1,950	7,760	1,450	7,040	1,290	5,560	980

*For cutting depth (ap, ae), refer to the above conditions for each section.

■ Angle range of barrel R and tip R

Depending on the cutting shape, the contact section is divided into barrel R and tip R. Check the contact section and select the appropriate cutting conditions according to each section.

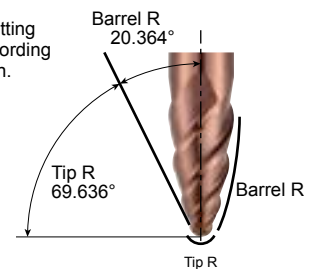

Determine the ap value based on the desired cusp height by selecting it from the table below.

Tool		Cusp height (mm)					
Item code	Barrel R	0.0001	0.0003	0.0005	0.001	0.003	0.005
GS4TN2.5-12.5R-TH3	12.5	0.10	0.17	0.22	0.32	0.55	0.71
GS4TN3.75-18.75R-TH3	18.75	0.12	0.21	0.27	0.39	0.67	0.87
GS4TN5-25R-TH3	25	0.14	0.24	0.32	0.45	0.77	1.00
GS4TN7.5-37.5R-TH3	37.5	0.17	0.30	0.39	0.55	0.95	1.22
GS4TN10-50R-TH3	50	0.20	0.35	0.45	0.63	1.10	1.41

[Note]

- ① Use the appropriate coolant for the work material and machining shape.
- ② Use a machine having as high rigidity and high accuracy as possible.
- ③ These conditions are for general guidance; in actual machining conditions adjust the parameters according to your actual machine and work-piece conditions.
- ④ If the rpm of the machine is low, lower the feed rate also to put the rpm and feed rate in the same ratio.

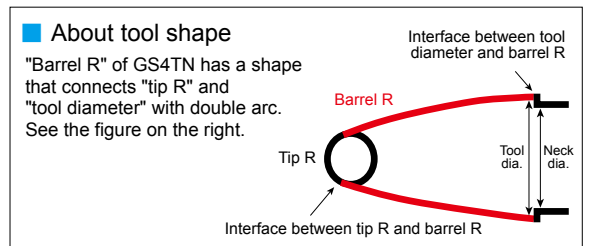

Field data

In 3-axis machining evaluation test of machining surface step between barrel R and tip R GP1T

Cutting conditions

Work material : SKD61(52HRC)
 GP1Tφ20-TH308
 OH=88mm
 $n=7,970\text{min}^{-1}$
 $v_f=960\text{mm/min}$
 Cusp height setting value : 0.001mm
 Air-blow, Down cut

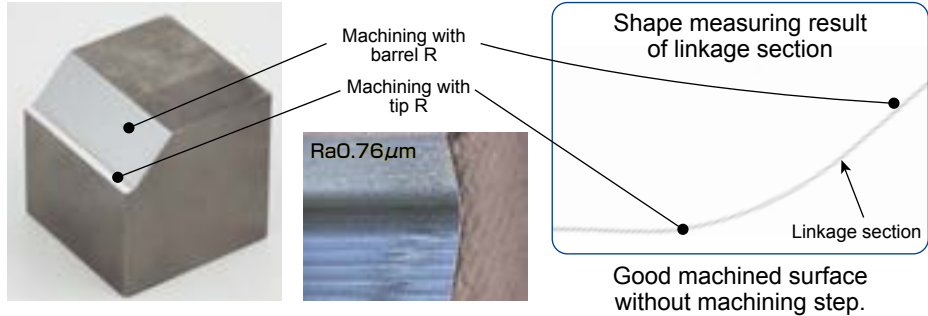

Model machining of YXR 33 with 5-axis machine Hi-Pre² GS4TN

Tool : GS4TN10-50R-TH3 Machine : 5-axis machine, Air blow Work material : YXR33(58HRC) Machining depth : 30mm
 Work size : About 90mm Finishing time : **About 2 hours.** CAD/CAM : hyperMILL

Process	Tool	Working area	Flute shape	Revolution n (min ⁻¹)	Cutting speed V_c (m/min)	Feed rate V_f (mm/min)	Feed per tooth f_z (mm/t)	Depth of cut a_p (mm)	Depth of cut a_e (mm)	Cutting time (min)
Roughing	HGOF4100-20-TH		Radius	2,200	69.1	1,760	0.2	0.4	3	92
Finishing	ETM4060-15-H		Radius	3,700	69.7	1,780	0.12	0.24	3	13
Semi-finishing	GS4TN5-25R-TH3 (O/H:30mm)	①	Barrel edge	10,560	165.8	1,440	0.034	0.6	0	46
		②	Tip edge	15,900	249.6	2,060	0.032	0	0.15	
Finishing	GS4TN3.75-18.75R-TH3 (O/H:25mm)	③	Barrel edge	11,370	127.5	1,640	0.036	0.5	0	92
		④	Tip edge	18,500	207.4	1,800	0.024	0	0.7	

**Possible to finish tilted section and fillet section (connection surface) with one tool.
 Good machined surface without machining steps which caused by tool change.**

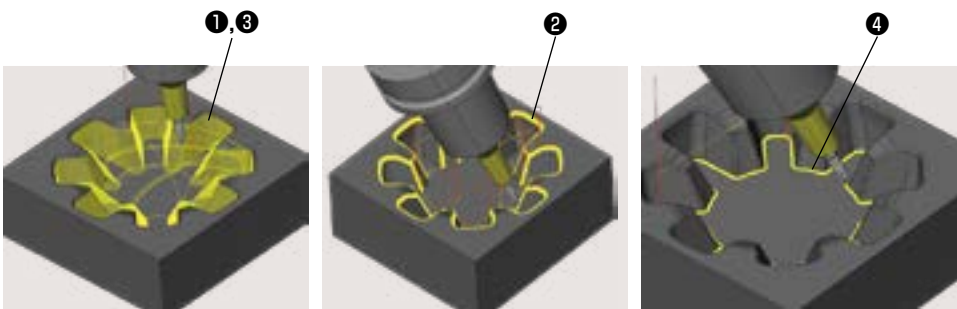

The same tool could finish even fillet section.



Surface roughness is good even when cutting with large pitch

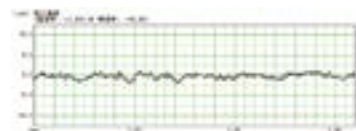

Ra:0.515µm Rz:2.574µm



Curved surface finishing of eyeglass shape

GF3L

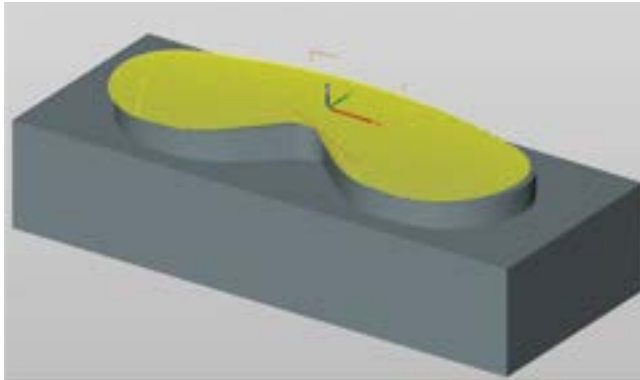

Work material : STAVAX Machine : 5 axis M/C (HSK-A63)

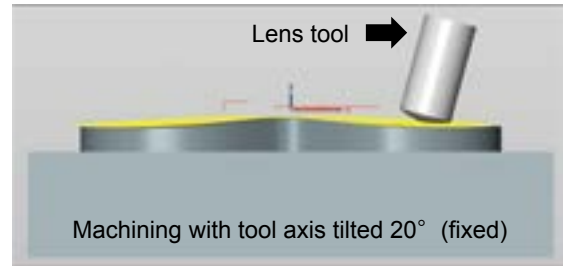

$v_c=392\text{m/min}$, $f_z=0.17\text{mm/t}$, $a_p=0.1\text{mm}$,
Cusp height =0.003mm, wet, $D_c=25\text{mm}$, 3NT

Cutting efficiency about doubled with the similar surface roughness as ball end mill.



Semi-finishing of gentle sloped surface. (3 axis M/C)

GF3L

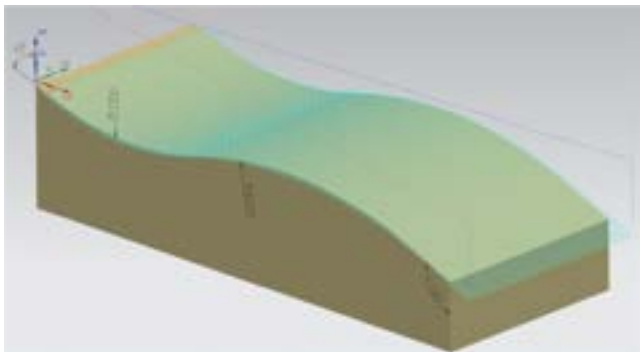

Work material : HPM(P20) Machine : 3 axis vertical M/C (HSK-A63)

By utilizing GF3L type for semi-finishing after contouring roughing by radius mill, it is possible to the cutting about double efficiency of the ball end mill.

Using the GALLEA series (GF3L, GP1LB) it is possible to process from semi-finishing to finishing with high efficiency

Process	Tool	Grade	Cutting conditions									Cutting time
			v_c (m/min)	n (mm ⁻¹)	v_f (mm/min)	f_z (mm/t)	a_p (mm)	a_e (mm)	Cusp height (mm)	Removal stock (mm)	Method	
Roughing	RD16B4032S32	GX2160	200	2000	2400	0.4	0.8	10	—	0.6	Contouring	27' 28"
Semi-roughing	GF3L25M-3-M12	PN215	200	2546	3820	0.5	0.5	(2)	0.02	0.1	Surface machining	3' 57"
Finishing	GP1LB25M-M12	PN215	720	9180	4590	0.25	0.1	—	0.003	0	Surface machining	6' 30"



Turbine blade finishing

GF3L

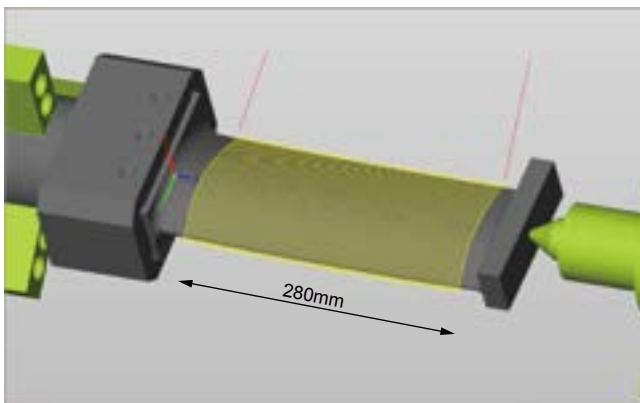

Work material : SUS420J2
Machine : Multi-function machine (HSK-A63)



Surface roughness

↓ $R_a=0.71\mu\text{m}$
 $R_z=3.52\mu\text{m}$

↶ $R_a=9.74\mu\text{m}$
 $R_z=34.6\mu\text{m}$

$v_c=500\text{m/min}$, $f_z=0.4\text{mm/t}$, $v_f=7,640\text{mm/min}$,
 $a_p=0.5\text{mm}$, Cusp height=0.02mm, wet,
 $D_c=25\text{mm}$, Simultaneous 5-axis machining
Heal angle : 10° Fixed
GF3L25M-3-M12 / TPHW1303-25 PN215

Possible to high efficiency finishing by using GF3L type.

Three-axis machining of auto mobile C pillar outer plate model GP1LB

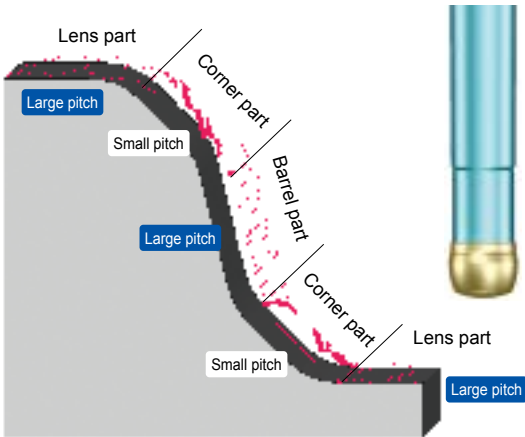

Combining high efficiency and high quality machining

Work material : DAC (43HRC) Machine : BT50 class
CAD/CAM : tebis

Roughing①: **About 4 hours.**

φ42mm High feed tool TD4N type

Roughing②: **About 50 min.**

φ20mm Ball end mill BCF type

Semi-finishing · finishing : **About 8 hours.**

φ20mm Ball end mill ABPF type

φ20mm GALLEA GP1LB type
ZPHW200-LB PN215

φ16mm Ball end mill ABPF type

φ10mm Ball end mill EMBE

φ6mm Ball end mill EMBE

Total cutting time : **About 13 hours**



After roughing

Unequal part after roughing process can be machined with efficiency of 1.4 times the conventional ball end mill.



After finishing

Surface roughness improved by 40% with the same processing time as conventional ball end mill.

Three-axis machining of automobile door panel model GP1LB



By separately using the GALLEA series and conventional tool, you can process the rest of fillets speedy and with high quality. For high hardened steel, GP1LB can be processed with efficiency of about 1.4 times that of a conventional ball end mill of same diameter.

Work material : SLD-MAGIC (60HRC) Machine : BT40 class
CAD/CAM : WorkNC

Process	Tool	Cutting speed vc (m/min)	Revolution n (min ⁻¹)	Feed per tooth fz (mm/t)	Feed rate vf (mm/min)	Depth of cut ap (mm)	Depth of cut ae (mm)	Cusp height (μm)	Removal stock (mm)	Coolant
Roughing	RH2P1016S-4 EPHW0402TN-2 JP4105	65	1,290	0.3	1,540	0.1	6.5	—	0.2	Air-blow
Semi-finishing	All GP1LB20M-M10 ZPHW200-LB20 TH308	200	3,183	0.2	1,273	0.05	1.0	6	0.1	Air-blow
	Corner etc. EHHB4080-ATH	136	5,400	0.09	1,905	0.3	0.6	11	0.1	Air-blow
	Corner etc. EHHB4050-ATH	135	8,600	0.05	1,840	0.2	0.4	8	0.1	Air-blow
Finishing	All GP1LB20M-M10 ZPHW200-LB20 TH308	200	3,183	0.2	1,273	0.05	0.57	2	0	Air-blow
	Corner etc. EHHB4080-ATH	161	6,400	0.08	2,050	0.05	0.25	2	0	Air-blow
	Corner etc. EHHB4050-ATH	160	10,200	0.05	1,980	0.05	0.20	2	0	Air-blow

Total cutting time : **About 4 hours**



Comparison of machined surface with the same pick.

GP1LB

Work material : FCD600
 Tool : GP1LB30M-M16 ZPHW300-LB TH308
 Conventional ball end mill $\phi 30\text{mm}$
 $n=6,000\text{min}^{-1}$ $v_c=565\text{m/min}$
 $v_f=6,000\text{mm/min}$
 Pitch=0.6mm Removal stock=0.1mm

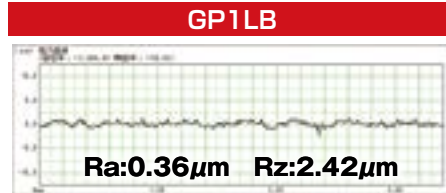
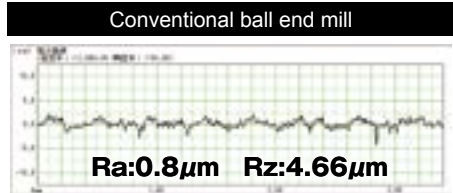
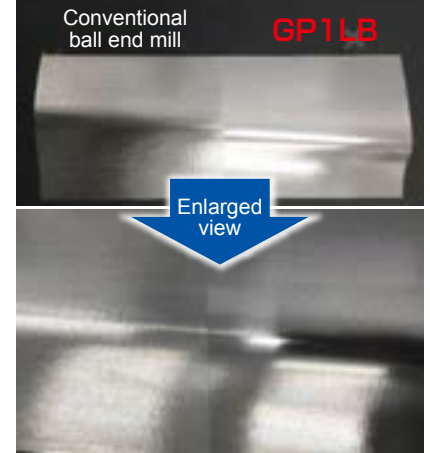
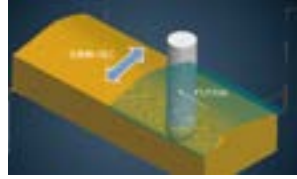

Surface roughness is about 1/2 of the ball end mill.



Part of door-inner model for automobile (3-Axis)

GP1LB

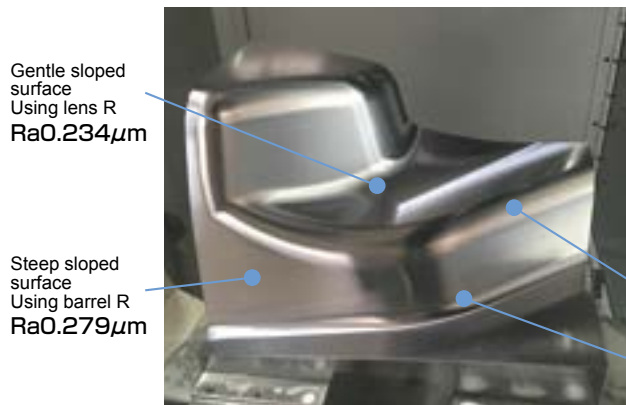

POINT

Combination of lens tool and barrel tool steep-slope and gentle-slope can be finished with single tool

About 1.3 times as compared with conventional ball end mill

Work material : NAK80(42HRC)
 Machine : BT40 class CAD/CAM : FF CAM

For fillet processing, use connection-R edge.

Corner R was processed using ball end mill.
 Processing is completed, there is no connecting step on the surface.

Process	Tool	Tool dia.	Cutting conditions							
			v_c (m/min)	n (mm^{-1})	v_f (mm/min)	f_z (mm/t)	Pitch (mm)	Cutting amount (mm/t)	Coolant	
Semi-finishing	Gentle sloped surface	GP1LB16M-M8 ZPHW160-LB16 PN215 (Lens R:16, Barrel R:16)	16	231	4,600	1,840	0.2	1.6	0.15	Mist
	Steep sloped surface		16	181	3,600	1,440	0.2	1.6	0.15	Mist
Finishing	Gentle sloped surface		16	231	4,600	1,840	0.2	0.25	0.05	Mist
	Steep sloped surface		16	181	3,600	1,440	0.2	0.25	0.05	Mist



The diagrams and table data are examples of test results, and are not guaranteed values.
 "MOLDINO" is a registered trademark of MOLDINO Tool Engineering, Ltd.

Attentions on Safety

1. Cautions regarding handling

- (1) When removing the tool from its case (packaging), be careful that the tool does not pop out or is dropped. Be particularly careful regarding contact with the tool flutes.
- (2) When handling tools with sharp cutting flutes, be careful not to touch the cutting flutes directly with your bare hands.

2. Cautions regarding mounting

- (1) Before use, check the outside appearance of the tool for scratches, cracks, etc. and that it is firmly mounted in the collet chuck, etc.
- (2) When preparing for use, be sure that the inserts are firmly mounted in place and that they are firmly mounted on the arbor, etc.
- (3) If abnormal chattering, etc. occurs during use, stop the machine immediately and remove the cause of the chattering.

3. Cautions during use

- (1) Before use, confirm the dimensions and direction of rotation of the tool and milling work material.
- (2) The numerical values in the standard cutting conditions table should be used as criteria when starting new work. The cutting conditions should be adjusted as appropriate when the cutting depth is large, the rigidity of the machine being used is low, or according to the conditions of the work material.
- (3) Cutting tools are made of a hard material. During use, they may break and fly off. In addition, cutting chips may also fly off. Since there is a danger of injury to workers, fire, or eye damage from such flying pieces, a safety cover should be attached when work is performed and safety equipment such as safety goggles should be worn to create a safe environment for work.
- (4) There is a risk of fire or inflammation due to sparks, heat due to breakage, and cutting chips. Do not use where there is a risk of fire or explosion. **Please caution of fire while using oil base coolant, fire prevention is necessary.**
- (5) Do not use the tool for any purpose other than that for which it is intended.

4. Cautions regarding regrinding

- (1) If regrinding is not performed at the proper time, there is a risk of the tool breaking. Replace the tool with one in good condition, or perform regrinding.
- (2) Grinding dust will be created when regrinding a tool. When regrinding, be sure to attach a safety cover over the work area and wear safety clothes such as safety goggles, etc.
- (3) This product contains the specified chemical substance cobalt and its inorganic compounds. When performing regrinding or similar processing, be sure to handle the processing in accordance with the local laws and regulations regarding prevention of hazards due to specified chemical substances.

MOLDINO Tool Engineering, Ltd.

Head Office

Hulic Ryogoku Bldg. 8F, 4-31-11, Ryogoku, Sumida-ku, Tokyo, Japan 130-0026
 International Sales Dept. : TEL +81-3-6890-5103 FAX +81-3-6890-5128

Official Web Site

<http://www.moldino.com/en/>

Database for selection Cutting Tool Products **[TOOL SEARCH]**

TOOLSEARCH

Search Web 

Europe **MOLDINO Tool Engineering Europe GmbH**
 Itterpark 12, 40724 Hilden, Germany.
 Tel +49-(0)2103-24820 Fax +49-(0)2103-248230

China **MOLDINO Tool Engineering (Shanghai), Ltd.**
 Room 2604-2605, Metro Plaza, 555 Loushanguan Road, Changning District, Shanghai, 200051, China
 Tel +86-(0)21-3366-3058 Fax +86-(0)21-3366-3050

America **MITSUBISHI MATERIALS U.S.A. CORPORATION**
DETROIT OFFICE Customer service
 41700 Gardenbrook Road, Suite 120, Novi, MI 48375-1320 U.S.A.
 Tel +1(248) 308-2620 Fax +1(248) 308-2627
CHICAGO OFFICE
 1314B North Plum Grove Road, Schaumburg, IL 60173 U.S.A.
 Tel +1(847) 252-6371 Fax +1(248) 308-2627

Mexico **MMC METAL DE MEXICO, S.A. DE C.V.**
 Av. La Cañada No.16, Parque Industrial Bernardo Quintana, El Marques, Querétaro, CP 76246, México
 Tel +52-442-1926800

Brazil **MMC METAL DO BRASIL LTDA.**
 Rua Cincinato Braga, 340 13° andar, Bela Vista – CEP 01333-010 São Paulo – SP., Brasil
 Tel +55(11)3506-5600 Fax +55(11)3506-5677

Thailand **MMC Hardmetal (Thailand) Co.,Ltd. MOLDINO Division**
 622 Emporium Tower, Floor 22/1-4, Sukhumvit Road, Klong Tan, Klong Toei, Bangkok 10110, Thailand
 TEL:+66-(0)2-661-8175 FAX:+66-(0)2-661-8176

India **Hitachi Metals (India) Pvt. Ltd.**
 Plot No 94 & 95, Sector 8, IMT Manesar, Gurgaon-122050, Haryana, India
 Tel +91-124-4812315 Fax +91-124-2290015

DISTRIBUTED BY: